



Elite Heating Boiler Submittal

JOB NAME:

LOCATION:

ARCH./ ENGR:

WHOLESALE:

MECH. CONTRACTOR:

MODEL NUMBER:

TYPE OF GAS:

BTU/HR INPUT LOW FIRE:

BTU/HR INPUT HIGH FIRE:

Heat Exchanger

- All Stainless Steel Construction 160 PSI ASME Stamped Construction National Board listed
- Gasket less Heat Exchanger Design
- PSI Relief Valve
- Front service access to combustion chamber and burner
- Inlet and outlet temperature sensor

Combustion System

- Modulating burner with 5 to 1 turndown
- Up to 98% AFUE / 95% Thermal Efficiency
- High Grade Inconel Burner Design
- Spark Ignition
- Models Available for Natural or LP Gas
- Dual Flame monitoring (Spark and Flame probe)

Integrated Control System

- Digital operating control with LED display with LED indicators for System Pump-Boiler Pump-DHW-Pump-System Fault –System operation
- Password Protected
- Outdoor reset with Indirect Priority
- Multiple Pump 120 volt pumps outputs – Boiler Pump – System Pump – DHW Pump
- 24 Volt monitoring
- 0-10 VDC input for Building Management System
- Boiler Output regulation (Adjustment of boiler output down to 50 percent of rated capacity)
- Cascade up to 8 boilers

Additional Features

- Combination Outlet Fitting to simplify connections.
- Superior condensate collection system with float switch
- Vents in Plastic PVC - CPVC - Stainless Steel
- Vents up 200 equivalent feet (Combined)
- 12 Year Limited Warranty
- Manual reset High temperature limit
- Adjustable leveling legs
- Field wiring board / Cascade wiring CAT 5 /CAT 3
- Dry contact for alarm output

Optional

- System Sensor (Part # 7250P-324)
- Indirect Sensor (Part # 7250P-325)
- 3” PVC Concentric vent Kit (#KGAVT0601CVT)
- 3” Stainless Steel Outside Termination Vent Kit (V1000)
- 4” Stainless Steel Outside Termination Vent Kit (V3000)
- 6” Stainless Steel Outside Termination Vent Kit (V4000)
- Flow Switch (Part # 7450P-213)
- Condensate Neutralizer (#7450P-212 for EL-80/110/150/220/299) (#7350P-611 for EL-399)
- U.L. 353 Compliant Low Water Cut-Off Interface Kit w / Manual Reset (Part # 7450P-225)
- Alarm System (Part # 7350P-602) to monitor any failure
- PC Connection Cable w / Software (Part # 7350P-320)

ELITE BOILER SERIES

- EXHAUST VENT CONNECTION (1)
- COMBUSTION AIR INLET CONNECTION (2)
- ELECTRICAL CONNECTIONS (3)
- SYSTEM RETURN (4)

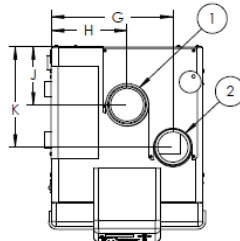

- (5) SYSTEM SUPPLY WITH INTEGRATED RELIEF VALVE
- (6) CONDENSATE CONNECTION
- (7) GAS LINE CONNECTION
- (8) DISPLAY/CONTROL PANEL
- (9) AIR RELEASE VENT

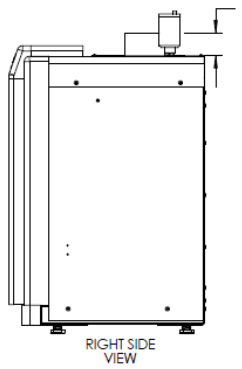
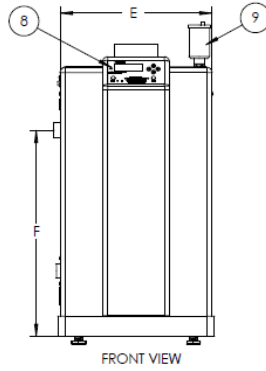
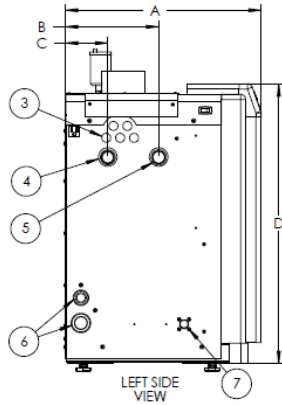

MODEL*	A	B	C	D	E	F	G	H	J	K	L	SHIPPING WEIGHT
EL-80	18.50	9.00	2.50	27.25	14.50	20.00	11.75	7.38	5.75	10.00	2.18	108
EL-110	18.50	9.00	2.50	27.25	14.50	20.00	11.75	7.38	5.75	10.00	2.18	113
EL-150	19.50	10.50	2.50	27.25	14.50	20.00	11.75	7.38	4.25	8.50	2.18	126
EL-220	26.50	17.50	6.00	27.25	14.50	20.00	11.75	7.38	4.25	8.50	2.18	164

MODEL	BTU/INPUT LOW FIRE	DOE HEATING	IBR	SUPPLY/RETURN	EXHAUST/AIR INLET	GAS CONNECTION
EL-80	16,000-80,000	14,600-73,000	63,000	1"	3"	3/4"
EL-110	22,000-110,000	20,200-101,000	88,000	1"	3"	3/4"
EL-150	30,000-150,000	27,400-137,000	119,000	1"	3"	3/4"
EL-220	44,000-220,000	40,600-203,000	177,000	1"	3"	1"

- EXHAUST VENT CONNECTION (1)
- COMBUSTION AIR INLET CONNECTION (2)
- ELECTRICAL CONNECTIONS (3)
- SYSTEM RETURN (4)

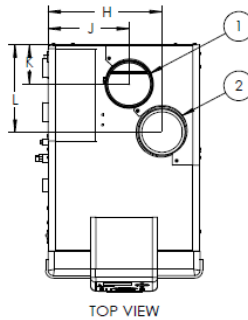

- (5) SYSTEM SUPPLY
- (6) RELIEF VALVE
- (7) CONDENSATE CONNECTION
- (8) GAS LINE CONNECTION
- (9) DISPLAY/CONTROL PANEL

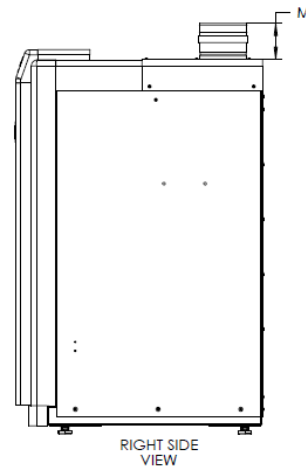
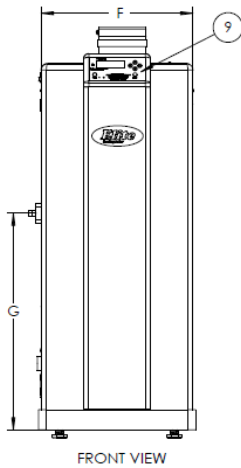
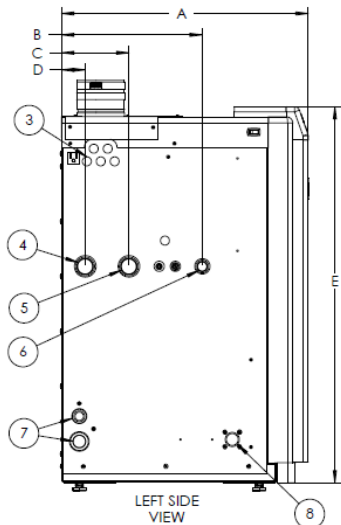

MODEL*	A	B	C	D	E	F	G	H	J	K	L	M	SHIPPING WEIGHT
EL-299	23.75	13.50	6.38	2.25	36.50	14.50	21.00	11.00	7.88	3.63	8.50	3.00	211
EL-399	30.75	20.50	9.75	2.75	36.50	14.50	21.00	11.00	7.88	3.63	8.50	3.00	256

MODEL*	BTU/INPUT LOW FIRE	DOE HEATING	IBR	SUPPLY/RETURN	EXHAUST/AIR INLET	GAS CONNECTION
EL-299	60,000 - 299,000	55,000 - 275,000	239,000	1-1/4"	4"	1"
EL-399	80,000 - 399,000	76,200 - 381,000	331,000	1-1/2"	4"	1"

* "N" DENOTES NATURAL GAS "LP" DENOTES PROPANE
 ALL DIMENSIONS ARE APPROXIMATE
 AND ARE SUBJECT TO CHANGE