

**OPERATING, INSTALLATION, AND SERVICE MANUAL**

# **SUPERstor** **CONTENDER**

*WITH FLOW COAT TECHNOLOGY*

---

**INDIRECT WATER HEATERS**

---



|                  |  |
|------------------|--|
| Manufactured by: | HEAT TRANSFER PRODUCTS, INC<br>120 BRALEY ROAD<br>P.O. BOX 429<br>EAST FREETOWN, MA 02717 U.S.A. |
| 508-763-8071     |  |



<http://www.htproducts.com>

LP-65 REV. 8.13.10

## CUTAWAY ILLUSTRATION

### INTRODUCING THE NEW SUPER-STOR CONTENDER

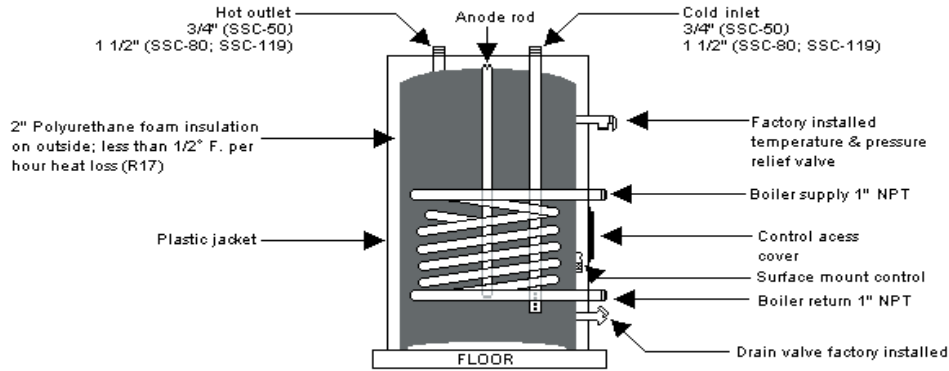

## SPECIFICATIONS AND PERFORMANCE RATINGS

| MODEL   | DIMENSIONS |      | CAPACITY<br>(US GALLONS) | HEAT EXCHANGER<br>RECOMMENDED. | HEAT EXCHANGER<br>PRESSURE | FIRST HOUR RATINGS* |       |
|---------|------------|------|--------------------------|--------------------------------|----------------------------|---------------------|-------|
|         | HT.        | DIA. |                          | FLOW RATE                      | DROP (FEET)                | 140°F               | 115°F |
| SSC-50  | 46 1/2"    | 23"  | 50                       | 8 GPM                          | 2.0                        | 160                 | 220   |
| SSC-80  | 71 1/4"    | 23"  | 80                       | 10 GPM                         | 3.2                        | 203                 | 276   |
| SSC-119 | 67"        | 28"  | 119                      | 12 GPM                         | 4.9                        | 308                 | 424   |

\*DOE TEST METHOD BASED ON 90°F. TEMPERATURE RISE, 55°/145° W/ BOILER WATER AT 180°F

| TANK SIZE | FLOOR TO<br>BOILER<br>SUPPLY | FLOOR TO<br>BOILER<br>RETURN | FLOOR TO<br>DOMESTIC<br>OUT | FLOOR TO<br>DRAIN<br>VALVE | DOMESTIC<br>CONNECTIONS | TEST<br>PRESSURE | WORKING<br>PRESSURE | SHIPPING<br>WEIGHT |
|-----------|------------------------------|------------------------------|-----------------------------|----------------------------|-------------------------|------------------|---------------------|--------------------|
| SSC-50    | 7 3/4"                       | 25 1/2"                      | 49 1/4"                     | 8 1/4"                     | 3/4" NPT MALE           | 300 PSI          | 150 PSI             | 170                |
| SSC-80    | 8"                           | 25 3/4"                      | 74"                         | 8 1/2"                     | 1 1/2" NPT MALE         | 300 PSI          | 150 PSI             | 232                |
| SSC-119   | 10 1/2"                      | 21 3/4"                      | 66 1/4"                     | 10 3/4"                    | 1 1/2" NPT MALE         | 300 PSI          | 150 PSI             | 331                |

**NOTE:** TANK RECOVERY FROM COLD START WILL BE BETWEEN 10-13 MINUTES WHEN SIZED WITH CORRECT FLOW RATE, BOILER SIZE AND PRESSURE DROP RATINGS FROM LIST IN ABOVE CHART. THE MASS OF THE BOILER WILL EFFECT RECOVERY TIME, MORE BOILER MASS EQUALS LONGER RECOVERY TIME.

## PERFORMANCE AND SIZING GUIDELINES

DETERMINE AMOUNT OF DOMESTIC HOT WATER NEEDED, THEN USE THE CHART BELOW TO OPTIMIZE SUPER STOR CONTENDER V.S. BOILER SIZING.

**NOTE:** MINIMUM BTU/H REQUIRED TO ACHIEVE FIRST HOUR RATING THE MASS OF THE BOILER WILL EFFECT RECOVERY TIME, MORE BOILER MASS EQUALS LONGER RECOVERY TIME.

| MODEL          | GROSS OUTPUT | 140° F<br>90° F. ΔT | 127° F<br>77° F. ΔT | 115° F<br>65° F. ΔT |
|----------------|--------------|---------------------|---------------------|---------------------|
| <b>SSC-50</b>  | 88,000       | 160                 | 188                 | 220                 |
| <b>SSC-80</b>  | 114,000      | 203                 | 239                 | 276                 |
| <b>SSC-119</b> | 161,000      | 308                 | 363                 | 424                 |

**NOTE:** ABOVE CHART IS BASED ON BOILER SIZE CONFORMING TO THE MINIMUM BTU/H REQUIRED TO ACHIEVE FIRST HOUR RATINGS, OBTAINABLE FROM CHART ABOVE. THE MASS OF THE BOILER WILL EFFECT RECOVERY TIME, MORE BOILER MASS EQUALS LONGER RECOVERY TIME.

### REDUCED BOILER INPUT, SIZING GUIDE

|                  |                          |                          |
|------------------|--------------------------|--------------------------|
|                  | 115° F    65°    ΔT      | 140° F    90°    ΔT      |
| <b>GROSS OUT</b> | <b>FIRST HOUR RATING</b> | <b>FIRST HOUR RATING</b> |
| <b>B.T.U.H.</b>  | <b>GALLONS</b>           | <b>GALLONS</b>           |

| <b>SSC-50</b>  |     |     |
|----------------|-----|-----|
| 20,000         | 79  | 60  |
| 40,000         | 119 | 90  |
| 60,000         | 159 | 121 |
| 80,000         | 208 | 153 |
| 100,000        | 220 | 160 |
| 120,000        | 220 | 160 |
|                |     |     |
| <b>SSC-80</b>  |     |     |
| 20,000         | 98  | 73  |
| 40,000         | 136 | 100 |
| 60,000         | 175 | 127 |
| 80,000         | 246 | 181 |
| 100,000        | 258 | 189 |
| 110,000        | 268 | 194 |
| 120,000        | 276 | 203 |
|                |     |     |
| <b>SSC-119</b> |     |     |
| 40,000         | 177 | 128 |
| 60,000         | 215 | 157 |
| 80,000         | 253 | 184 |
| 108,000        | 300 | 210 |
| 120,000        | 330 | 239 |
| 140,000        | 371 | 270 |
| 154,000        | 397 | 293 |
| 160,000        | 424 | 308 |

## LOCATION

Choose a location for your water heater centralized to the piping system. You must also locate the Super Stor Contender where it will not be exposed to freezing temperatures. Additionally, you will need to place the water heater so that the controls, drain and inlet/outlets are easily accessible. This appliance is certified for indoor use only and should not be installed outdoors. This unit should be kept vertical on a level surface. **[IMPORTANT CAUTION:** Care must be exercised when choosing the location of this appliance, where leakage from the relief valve, leakage from the related piping, or leakage from the tank or connections, will not result in damage to the surrounding areas, or to the lower floors of the building.] A water heater should always be located in an area with a floor drain or installed in a drain pan suitable for water heaters. Under no circumstances shall Heat Transfer Products Inc. be held liable for any such water damage whatsoever. **This water heater must not be located near flammable liquids such as Gasoline, Adhesives, Solvents, Paint Thinners, Butane, Liquefied Propane, etc.; as the controls of this appliance could ignite those vapors causing an explosion.**

## OPERATING YOUR SUPER STOR CONTENDER

Boiler high limit should be at least 20° higher than the Super Stor Contender temperature. Set the low limit of the boiler control at the minimum setting –this will call the burner on, only to satisfy the tank control.

We recommend a temperature setting of 119°F, or in accordance with local and state codes for normal operation. The differential is fixed at 3°-5°. You may prefer a setting of either higher or lower temperature, to satisfy your needs. A mixing valve in conjunction with a high temperature setting may be used for high demand applications (spas, hot tubs, whirlpools)

**NOTE:** RISK OF SCALD INJURY INCREASES AS YOU INCREASE WATER TEMPERATURE! IF DRAINING OF THE SUPER STOR CONTENDER IS NECESSARY, OPEN THE T & P VALVE OR A HOT WATER TAP TO PREVENT VACUUM BUILD UP IN THE TANK AND PIPING.

## PLUMBING

It is mandatory that all plumbing is done in accordance with all local and state plumbing codes or warranty will be voided. It is also necessary on all mechanical connections, that you use both thread tape and pipe dope.

**NOTE:** WHEN FILLING THE SUPER STOR CONTENDER, MAKE SURE THAT YOU OPEN THE HOT WATER TAP TO RELEASE THE AIR IN THE TANK AND PIPING.

## BOILER CONNECTIONS

Use a 1" nominal minimum tube size, where you are using zone valves or circulators, where a 1" zone valve and 1" tube is required.

On the tank, the boiler supply is to be connected to the outlet of the circulator. The inlet of the circulator is to be connected to the "HOT OUTLET" side of the boiler. Be sure that the arrow on the circulator is facing toward the flow direction. (See pressure drop sizing for circulator, page 5). On the tank, the boiler return is to be connected to the return side of the boiler. The return(s) from heating loop(s) should have a flow check or swing check valve installed before the return pipe from the tank.

In a steam boiler, the tank supply must be connected to the boiler, well below the minimum water level. A strainer and a drain valve should be installed at the boiler for periodic draining of scale and sludge. Banging and steam bound traps will occur if the boiler water supplied to the heat exchanger has steam or is slightly above the low water cut-out.

**NOTE:** THE CONTENDER HEAT EXCHANGER CANNOT BE USED WITH NON-BARRIER RADIANT TUBE SYSTEMS. USE ON CLOSED LOOP BOILER SYSTEMS ONLY.

## COLD WATER INLET

Use both thread tape and pipe dope to connect a NPT male X 3/4" (minimum) tube adapter. **[IMPORTANT CAUTION:** Dielectric fittings must be used.] A shut off valve between the city water supply and tank inlet is recommended for ease of service at a later date.

**[IMPORTANT CAUTION:** Exercise extreme caution when soldering, due to the plastic dip tube on both the hot water outlet and cold water inlet.] It may be recommended to use a back flow preventor –check your local codes. If a back flow preventor or a no return valve is used, a thermal expansion tank must be installed on the cold water supply, between the tank and valve. If the tank is replacing a tankless coil in the boiler, disconnect coil plumbing and use the cold inlet pipe and hot water outlet pipes for the Super Stor Contender tank. **DO NOT PLUG TUBE OUTLET IN TANKLESS COIL.**

## **! DANGER !**



Water temperature over 125° F can cause severe burns instantly, or death from scalds. Children, disabled, and elderly are at highest risk of being scalded, see instruction manual before setting temperature at water heater! Feel water before bathing or showering. Temperature limiting valves are available, see manual.

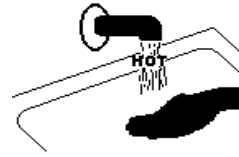

### **TEMPERATURE AND PRESSURE RELIEF VALVE**

A factory installed T & P valve long element, for hot water storage tanks (Required by local codes, but not less than the valve certified as meeting the requirements for relief valves for hot water heaters (ANSI Z212B-1984), by a nationally recognized lab that maintains periodic inspection of production of listed equipment, has been installed for your safety and convenience. If servicing, make sure that the relief valve is sized to the BTU/Hour capacity and storage capacity of the water heater. **The temperature and pressure relief valve must be plumbed down so discharge can exit only 6" above or at any distance below the structural floor and cannot contact any live electrical parts.** If the relief valve weeps, see expansion tank section for suggestions.

### **HOT WATER OUTLET**

Use both thread tape and pipe dope and connect a NPT male X 3/4 " (minimum) tube adapter. A shut off valve between hot water supply and tank outlet is recommended for ease of service at a later date. [IMPORTANT CAUTION: Dielectric fittings must be used.] [IMPORTANT CAUTION: Exercise extreme caution when soldering, due to the plastic dip tube on both the hot water outlet and cold water inlet.] [IMPORTANT CAUTION: A temperature limiting valve or mixing valve is not entirely necessary. Extreme caution on scalding is recommended if a temperature limiting or mixing valve is not used. See note above.]

### **CONTROL**

A surface mounted control is provided and mounted inside of the control access compartment. There is a insulation blanket under the control access cover to insure accurate readings of actual water temperature. The control is factory set at 118° for your safety (see "DANGER" above). The differential is fixed at 3° to 5°, (not adjustable).

### **WIRING**

All wiring is to be done in accordance with all applicable local and state codes. Turn off all power related to the boiler starting and wiring procedures. See pages 9 and 10. It is recommended that a disconnect switch be installed between the boiler control and water heater.

### **EXPANSION TANK**

A thermal expansion tank for hot potable water may be required and necessary to offset the expansion of the water as it is heated. If there is a back flow preventor or any other type of no return valve or check valve, the thermal expansion tank is mandatory. The expansion tank must be sized for the entire water volume of the hot water system. An indication of a required expansion tank, is a weeping relief valve. See Typical Expansion Tank on page 5.

## PRESSURE DROP SIZING FOR CIRCULATOR

You must have a flow rate, from the chart, on the boiler circulator for the boiler water or the published ratings cannot be achieved. The chart below represents the tube run, the water heater and the heat exchanger **ONLY** and does not include any flow checks, zone valves or friction loss through the boiler.

### PRESSURE DROP FOR TUBE LENGTH OF 1" COPPER, AND FOR SIX 90 DEGREE ELBOWS, AND ON TEE ON THE RUN

|                | TUBE SIZE | 20'  | 30'  | 40'  | 50'  | 60'  |
|----------------|-----------|------|------|------|------|------|
| <b>SSC-50</b>  | 8 GPM     | 3.71 | 4.28 | 4.85 | 5.42 | 6    |
| <b>SSC-80</b>  | 10 GPM    | 5.75 | 6.6  | 7.45 | 8.3  | 9.15 |
| <b>SSC-119</b> | 12 GPM    | 8.2  | 9.3  | 10.4 | 11.5 | 12.6 |

### TYPICAL MIXING VALVE

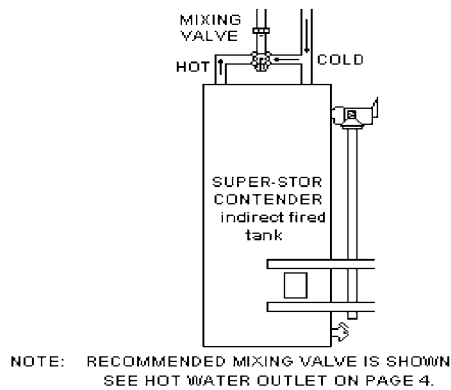

### TYPICAL EXPANSION TANK

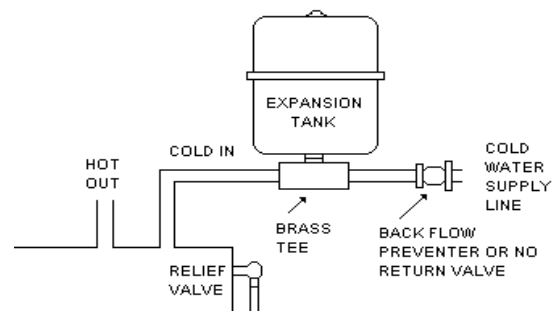

### TYPICAL INSTALLATION USING ZONE VALVES

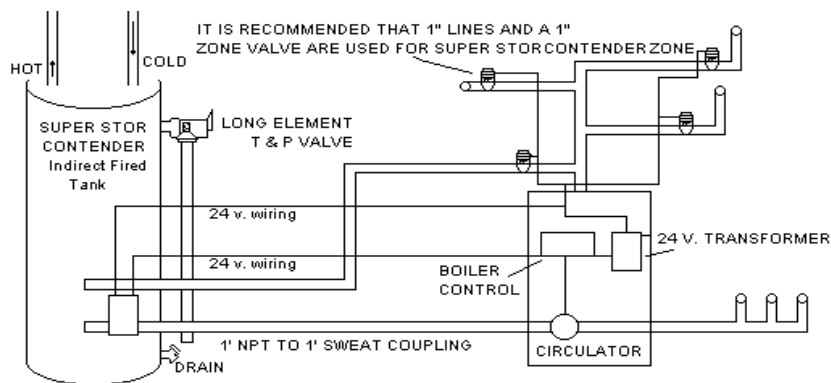

NOTE: IF A BACK FLOW PREVENTER OR A NO RETURN VALVE IS INSTALLED, A THERMAL EXPANSION TANK IS REQUIRED ON THE COLD WATER INLET BETWEEN THE SUPER STORE CONTENDER AND THE BACKFLOW PREVENTER.

TYPICAL INSTALLATION USING CIRCULATORS

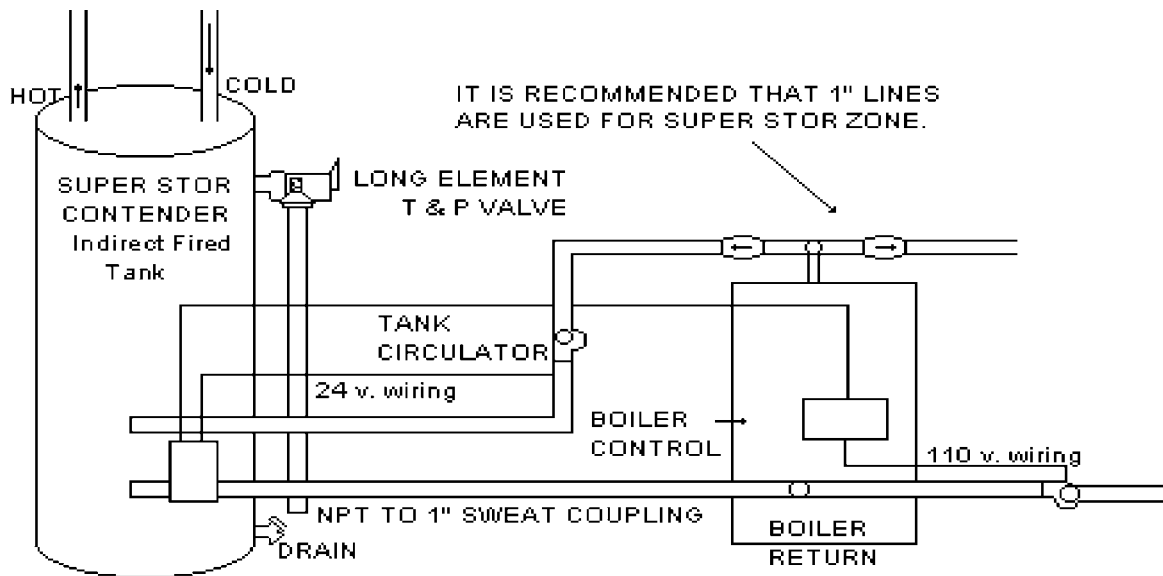

IT IS RECOMMENDED THAT 1" LINES ARE USED FOR SUPER STOR ZONE.

NOTE: RECOMENDED MIXING VALVE IS SHOWN. SEE HOT WATER OUTLET ON PAGE 4.

NOTE: IF A BACKFLOW PREVENTER OR A NO RETURN VALVE IS INSTALLED, A THERMAL EXPANSION TANK IS REQUIRED ON THE COLD WATER INLET BETWEEN THE CONTENDER AND THE BACKFLOW PREVENTER.

TYPICAL INSTALLATION USING A ZONE VALVE (3-WAY)

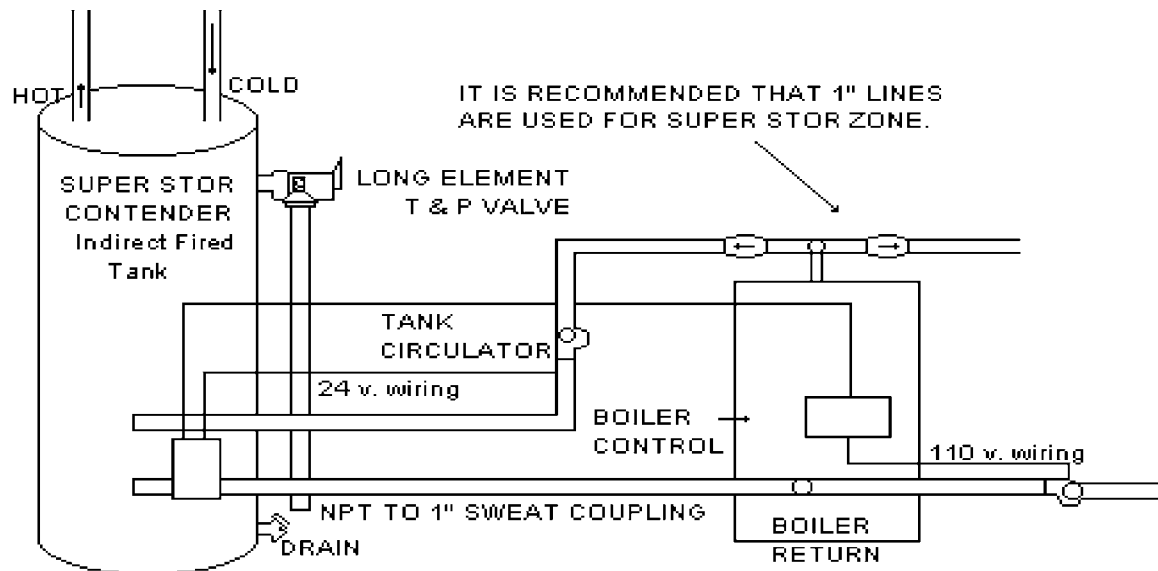

IT IS RECOMMENDED THAT 1" LINES ARE USED FOR SUPER STOR ZONE.

NOTE: IF A BACKFLOW PREVENTER OR A NO RETURN VALVE IS INSTALLED, A THERMAL EXPANSION TANK IS REQUIRED ON THE COLD WATER INLET BETWEEN THE SUPER STOR AND THE BACKFLOW PREVENTER.

## SUPER STOR CONTENDER WITH STORAGE TANK TYPICAL INSTALLATION

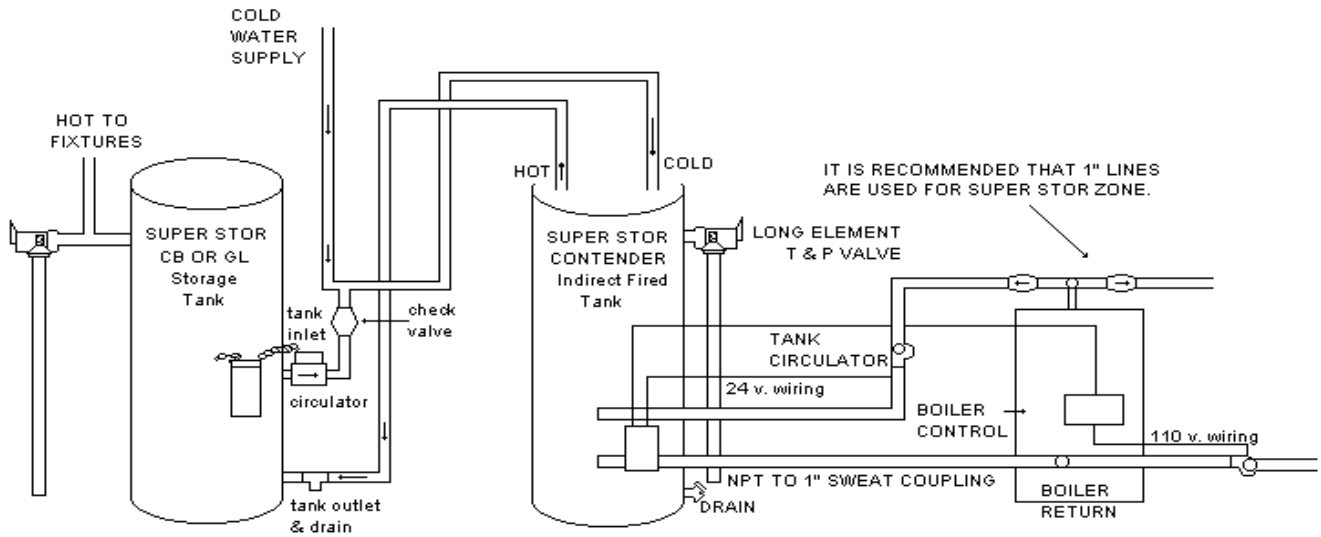

NOTE: IF A BACKFLOW PREVENTER OR A NO RETURN VALVE IS INSTALLED, A THERMAL EXPANSION TANK IS REQUIRED ON THE COLD WATER INLET BETWEEN THE SUPER STOR AND THE BACKFLOW PREVENTER.

## MULTIPLE TANK INSTALLATIONS

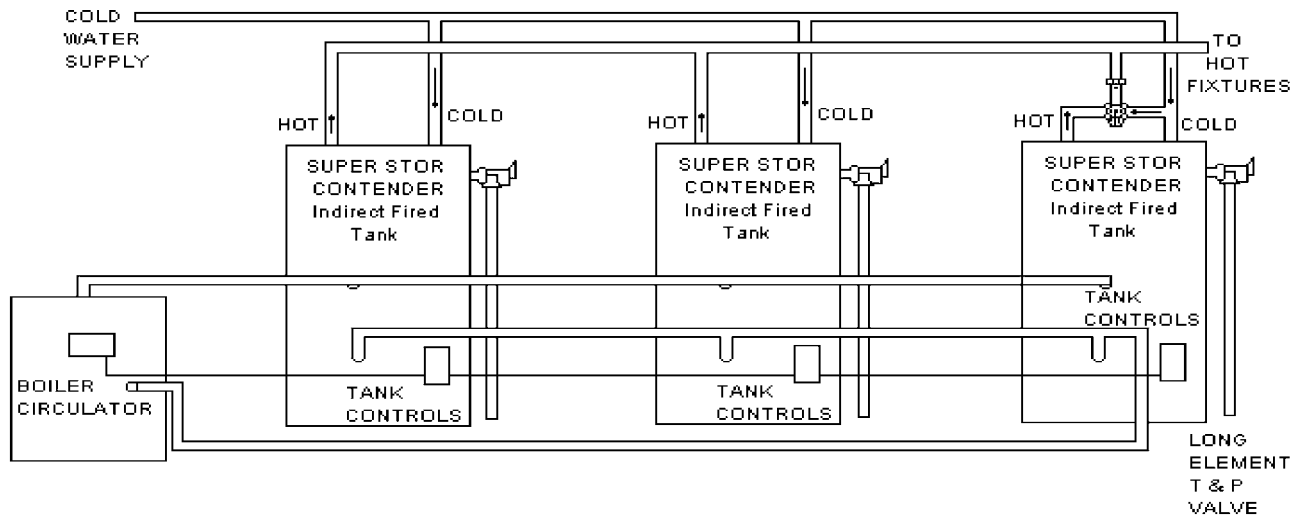

NOTE: ALL PIPING IN PARALLEL IS USED FOR LARGE DUMPS OF HOT WATER; HIGH USAGE, SHORT DURATION.

## TYPICAL STEAM BOILER

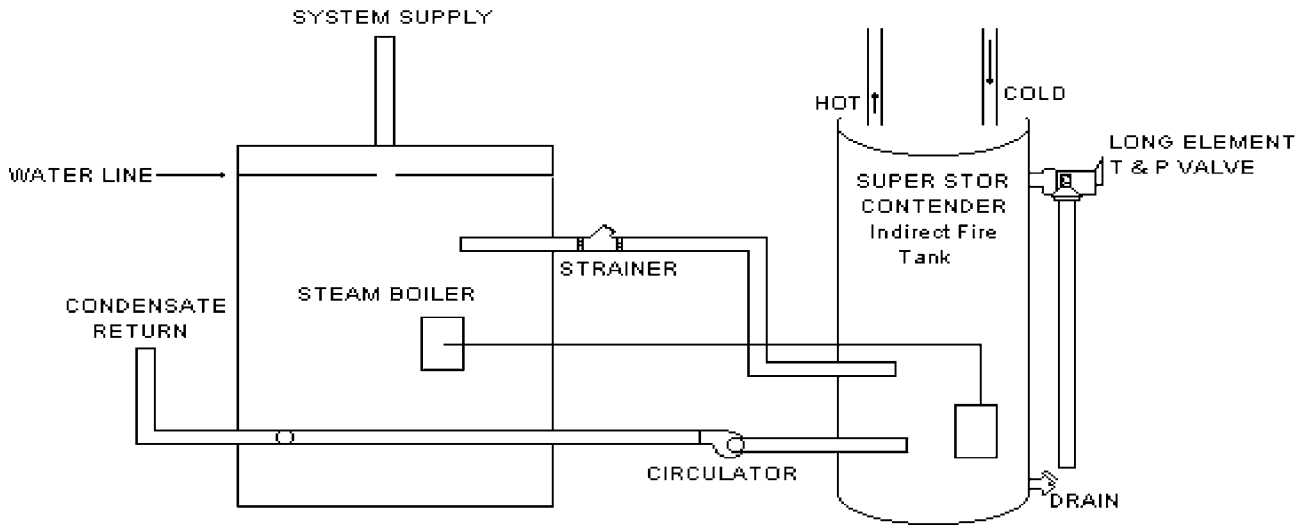

NOTE: WATER LINE MUST REMAIN ABOVE BOILER  
OUTLET TO WATER HEATER AT ALL TIMES.

## WIRING DIAGRAMS

### ZONING WITH CIRCULATORS USING R8182D AND R845A RELAY

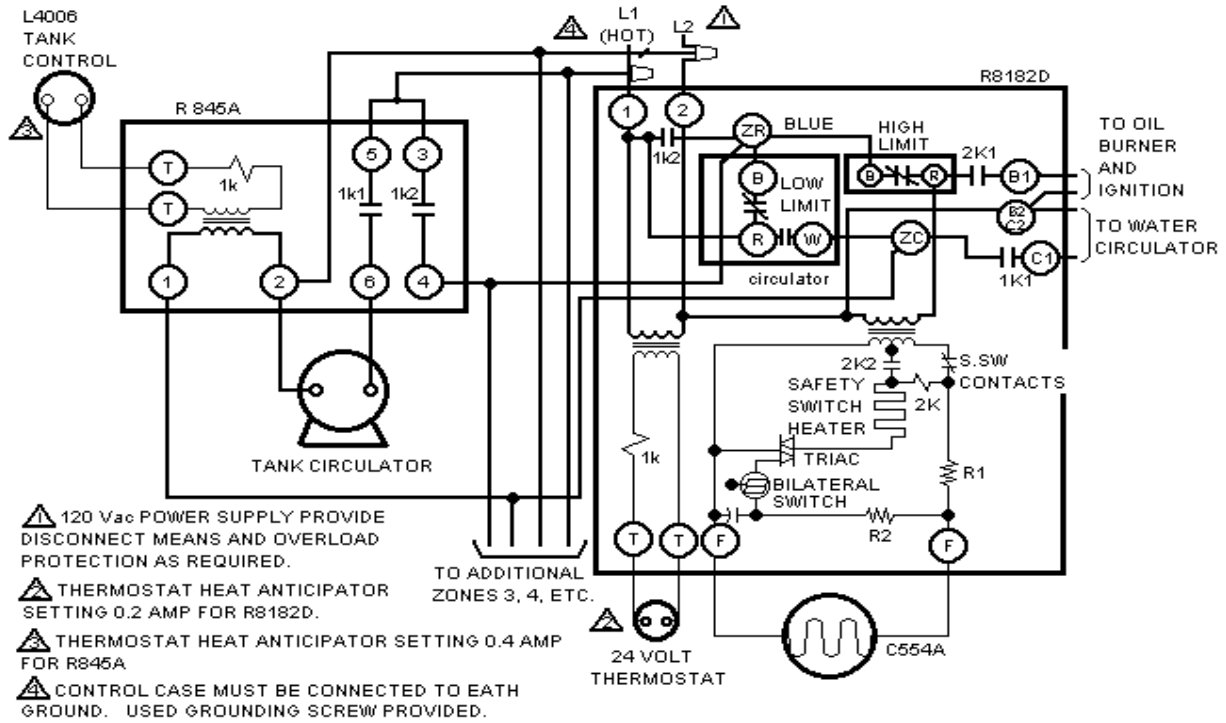

### ZONING WITH CIRCULATORS USING L8124 E-F AND R845A RELAY

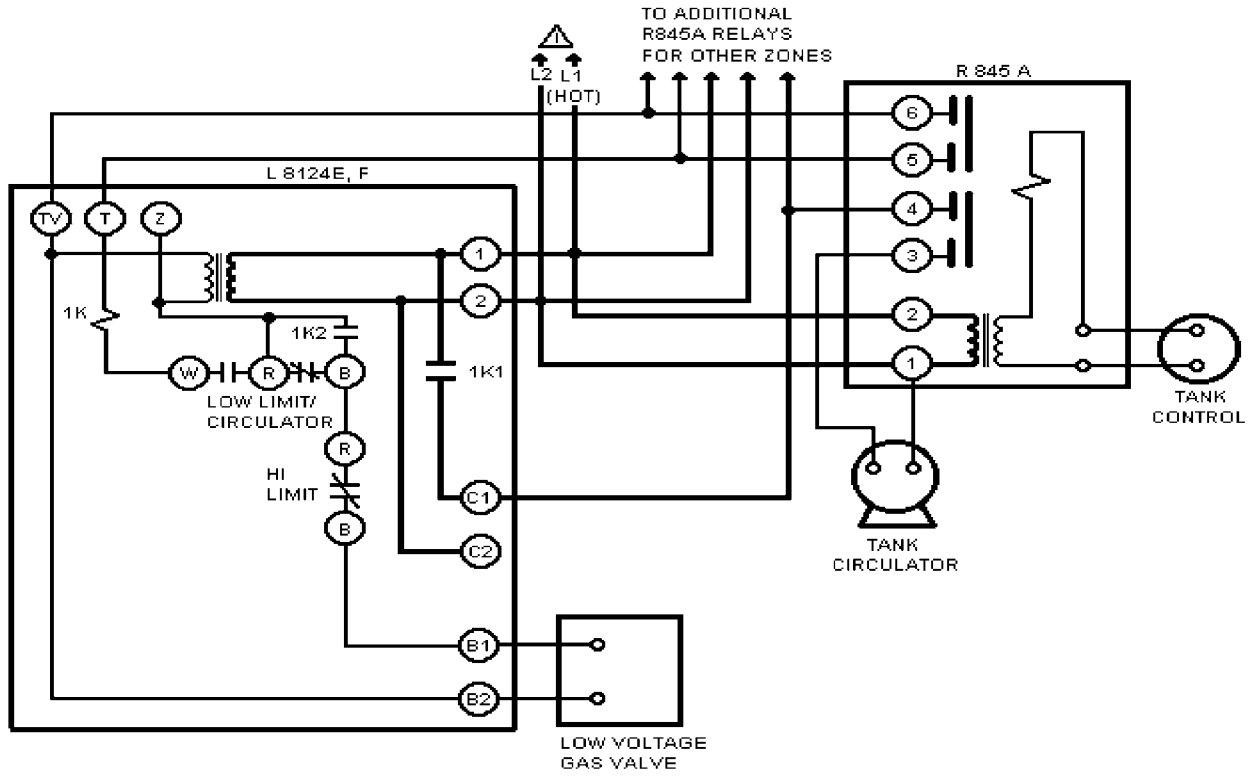

# WIRING DIAGRAMS

## USING L8148A OR L8152A COLD START BOILER CONTROL WITH CIRCULATORS

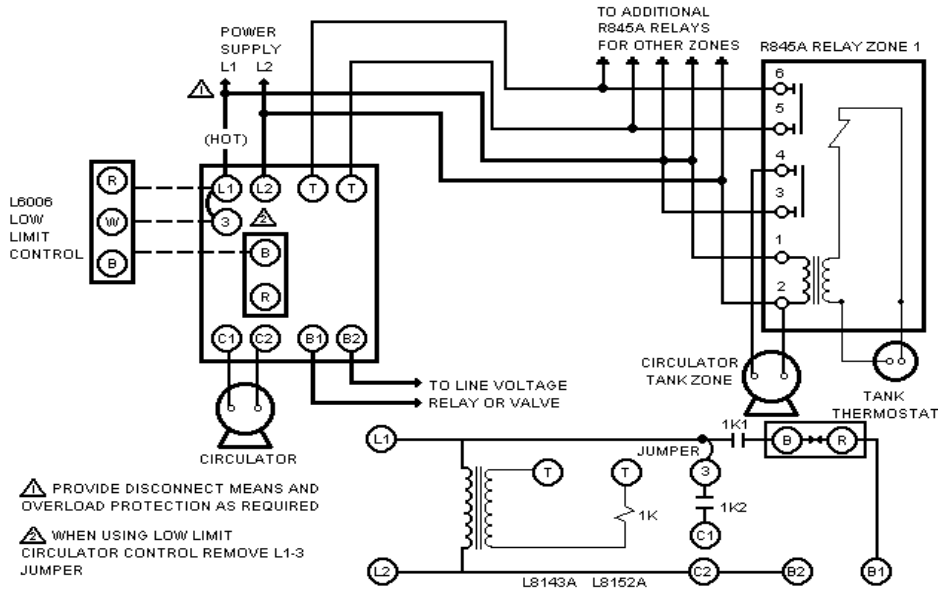

## USING L8143A OR L8152A COLD START BOILER CONTROL WITH ZONE VALVES

ZONE VALVE WIRING (24 VOLT)

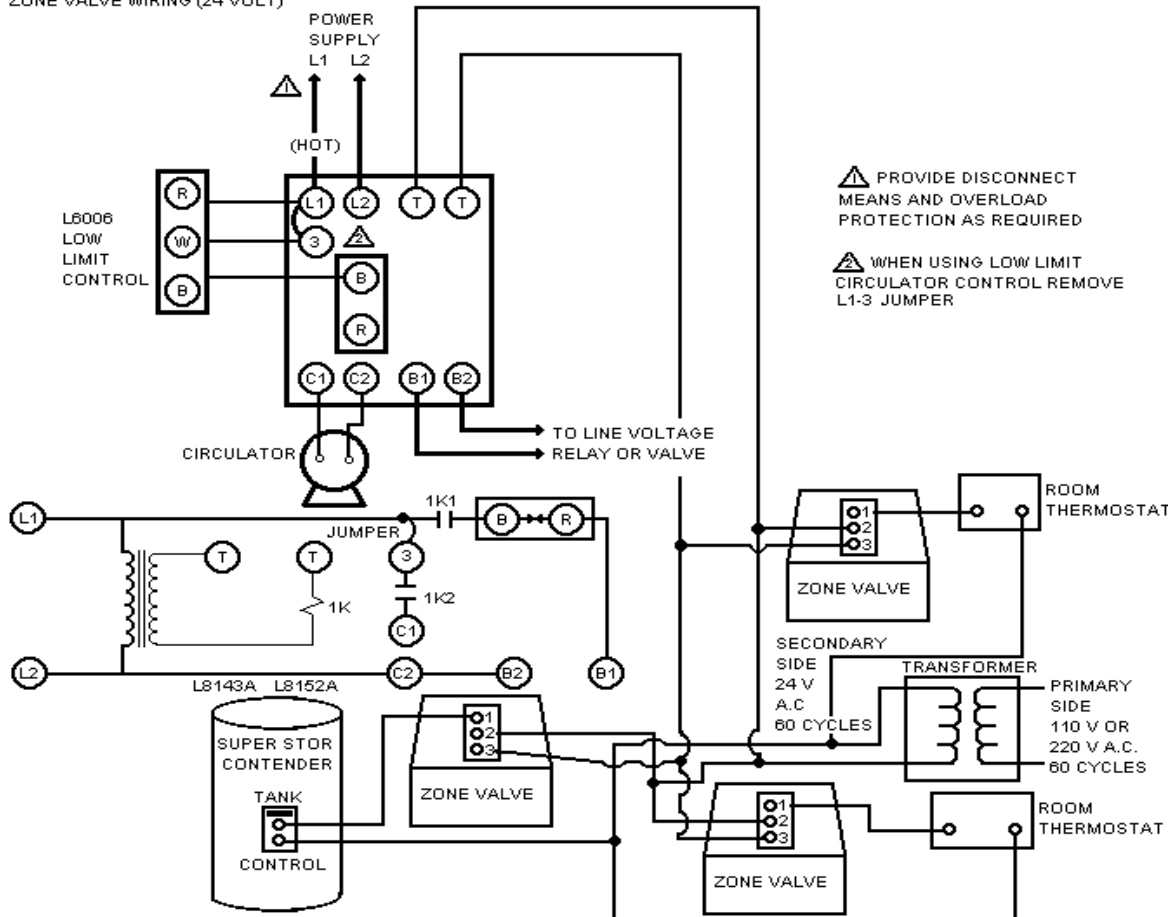

## TROUBLESHOOTING YOUR SUPER STOR CONTENDER

### NO HOT WATER

| PROBLEM:                      | POSSIBLE SOLUTION                                       |
|-------------------------------|---|
| A. ZONE VALVE NOT OPENING     | A. OPEN MANUALLY TO CHECK                               |
| B. CIRCULATOR NOT OPERATING   | B. CHECK OR REPLACE                                     |
| C. TANK CONTROL SET TOO LOW   | C. ***RAISE TANK TEMPERATURE (SEE IMPORTANT NOTE BELOW) |
| D. BOILER CONTROL SET TOO LOW | D. RAISE BOILER TEMPERATURE                             |
| E. WIRING INCORRECT           | E. RECHECK WIRING                                       |
| F. TANK CONTROL FAILURE       | F. REPLACE CONTROL                                      |
| G. ZONE VALVE FAILURE         | G. REPLACE VALVE  |
| H. CIRCULATOR FAILURE         | H. REPLACE CIRCULATOR                                   |
| I. AIR TRAP IN LOOP           | I. PURGE TO REMOVE AIR                                  |

### NOT ENOUGH HOT WATER

| PROBLEM:                        | POSSIBLE SOLUTION   |
|---------------------------------|---|
| A. ZONE VALVE RESTRICTION       | A. 1" FULL BORE REPLACE ZONE VALVE  |
| B. CIRCULATOR ARROW REVERSED    | B. REVERSE CIRCULATOR   |
| D. BOILER TEMPERATURE TOO LOW   | D. RAISE BOILER TEMPERATURE   |
| E. BOILER SIZED TOO SMALL       | E. CHECK SIZING CHART   |
| F. DEMAND FLOW RATE TOO HIGH    | F. CHECK SIZING CHART   |
| G. TANK SIZED TOO SMALL         | G. CHECK SIZING CHART   |
| H. DEMAND FLOW RATE TOO HIGH    | H. INSTALL MIXING VALVE, ***RAISE TANK TEMP (SEE NOTE BELOW)<br>INSTALL FLOW REGULATOR  |
| I. AIR TRAP IN LOOP             | I. PURGE TO REMOVE AIR  |
| J. HEAT & TANK COME ON TOGETHER | J. RE-CHECK WIRING OR COINCIDENCE<br>DRAW TANK DOWN AND LOWER HEAT THERMOSTAT. RE-CHECK |
| K. NOT ENOUGH SPACE HEAT        | K. BOILER SIZED TOO SMALL, CONSULT CHART  |
| L. SLOW RECOVERY                | L. CIRCULATOR HEAD CAPACITY TOO LOW   |

### T & P VALVE DISCHARGES

| PROBLEM:                     | POSSIBLE SOLUTION                  |
|------------------------------|------------------------------------|
| A. TANK TEMPERATURE TOO HIGH | A. LOWER TEMPERATURE ON TANK       |
| B. WATER EXPANDS WHEN HEATED | B. INSTALL EXPANSION TANK          |
| C. WATER PRESSURE TOO HIGH   | C. INSTALL PRESSURE REDUCING VALVE |

### HOT TUBS, SPAS, MULTIPLE SHOWERS, HIGH DEMAND

| PROBLEM:                 | POSSIBLE SOLUTION   |
|--------------------------|---|
| A. NOT ENOUGH HOT WATER  | A. CHECK FLOW RATE AND COMPARE TO CHART   |
| B. PRESSURE TOO LOW      | B. CHECK LINE PRESSURE FOR RESTRICTION  |
| C. RECOVERY OF TANK SLOW | C. SLOW START UP BOILER, SEE CHART  |
| D. NOT ENOUGH HOT WATER  | D. BOILER SIZED TOO SMALL, SEE CHART  |
|                          | DEMAND TOO GREAT, CHECK FLOW RATES AND COMPART TO CHART.<br>INSTALL MIXING VALVE AND OR A FLOW RESTRICTING ALVE AND ***RAISE<br>TANK AND BOILER TEMPERATURE (SEE NOTE BELOW). |

**\*\*\*NOTE:** WHEN RAISING TANK TEMPERATURE, YOU INCREASE THE RISK OF SCALDING - PLEASE USE A WATER TEMPERING OR MIXING VALVE AND EXTREME CAUTION. CONSULT CODES FOR CONFORMANCE. SEE PAGE 7. FOR EXAMPLE.

**MANUFACTURED BY:**

HEAT TRANSFER PRODUCTS, INC.; P.O. BOX 429, 120 BRALEY ROAD; EAST FREETOWN, MA 02717; 1-800-323-9651

OR VISIT OUR WEBSITE:

[WWW.HTPRODUCTS.COM](http://WWW.HTPRODUCTS.COM)