



Advanced Heating
& Hot Water Systems

Versa-Hydro™



96% Efficient

The cost effective
Versa-Hydro™
combines
space heating,
domestic hot water,
and total system
control into
one compact,
high efficiency
mod-con unit.

INNOVATION

The Most Innovative Hot Water And Heating System In The World Today

Product Versatility

Imagine a system that can provide hot water for the domestic system, radiant heating, hydro air and even solar assist all in one appliance. With the Versa-Hydro™ the designer has an extremely versatile appliance that can be used in many commercial and residential applications.



System Flexibility

The Versa-Hydro™ comes standard with auxiliary ports on the domestic storage side that allow contractors additional flexibility to easily install extra storage tanks or connect air handlers directly to the system. Whatever your requirements, the new Versa-Hydro™ can provide abundant hot water in one compact, highly-efficient appliance.



Domestic Hot Water

Modern homes along with current lifestyles, multiple bathrooms, and whirlpool tubs need larger amounts of hot water to meet peak demands. The Versa-Hydro™ is capable of delivering up to 314 gallons of hot water in the first hour with the added benefits of 96% Thermal Efficiency and an insulated tank that loses only ½ degree F per hour in standby heat loss.

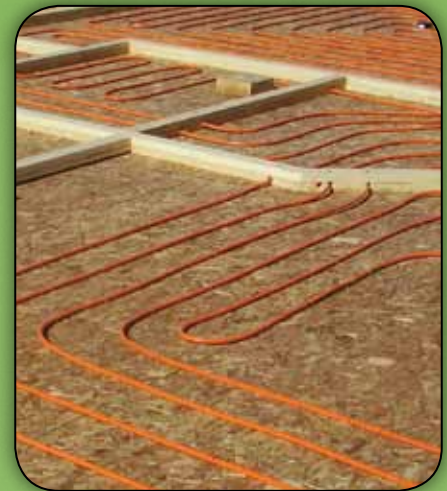

Hydronic Space Heating

The Versa-Hydro's™ advanced mod-con technology delivers a thermal efficiency of 96% and utilizes a 0 to 10 volt variable speed pump to reduce electrical and gas consumption without sacrificing comfort. The high-output heat exchanger generates up to 135,000 BTU/h for space heating, with system isolation for low-temperature baseboard, radiant heating and hydro air applications built in.

Superior Performance

Hydraulic Stabilization

The integrated space heating module utilizes the hydraulic mass stored in the tank to provide an abundant supply of energy for heat transfer. The thermal mass allows the appliance to draw heated water continuously from the tank which provides hydraulic stabilization to the system and prevents short-cycling. The entire unit is **96% thermal efficient** and the tank loses only ½ degree F per hour in standby heat loss. This allows the space heating module to utilize water from the DHW system efficiently without repetitive cycling of the burner.



Highly Efficient Condensing Technology

The major advantage of condensing technology is to extract more heat from the exhaust gas compared to conventional systems. The heat exchanger incorporates a larger surface area constructed of high-quality 90/10 cupronickel, which allows the unit to extract all of the latent energy from the water vapor contained within the exhaust gas. This reclamation of energy allows the appliance to use less fuel to meet desired heating loads.

Saves Fuel – Modulation Matters

The Versa-Hydro™ has an outstanding **5 to 1 turndown ratio** on the main combustion system and a **10 to 1 turndown ratio** on the space heating module. Greater turndown allows this appliance to modulate at lower firing rates, which conserves energy and improves component reliability. Modulation, along with thermal mass, eliminates the short-cycling effect of small zones or minimal DHW draws.

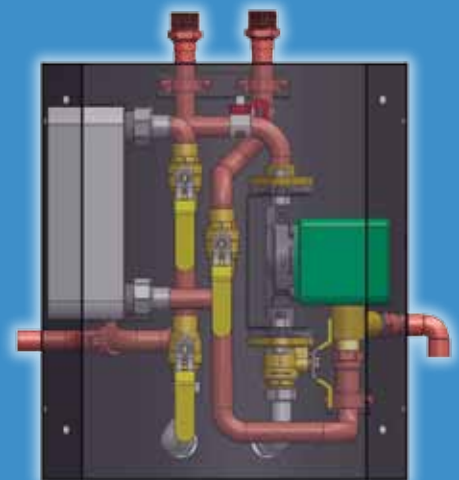

Virtually Maintenance Free

The Versa-Hydro™ is a virtually maintenance-free appliance. The robust material and sophisticated design of the appliance's heat exchanger minimizes buildup of lime and scale associated with hard water areas. The 5" diameter combustion tube and 1 1/8" secondary heat exchange spirals greatly enhance heat transfer and eliminate the blockage risk of small passageways that exist in low-mass boilers.

Space Heating Module

Total System Control

The Versa-Hydro™ Total System Control (TSC) manages pump speeds and temperature settings depending on the required BTU output. Contractors merely set the domestic tank temperature and the maximum heating temperature. The TSC will then automatically manage the appliance to provide the most efficient output depending on the load and outside temperature. This system gives contractors confidence that they are providing their customers with a product that is continuously maximizing efficiency.



Consumer Savings

Customer Savings

Impact of the American Recovery and Re-investment Act

Homeowners who purchase and install a qualifying HTP boiler or water heater could receive a substantial tax credit (check our web site for more details: www.htproducts.com).

In addition, many state and local governments and utility companies offer other incentives or rebates that can potentially further reduce the cost of installing energy-efficient products. An excellent source for additional information is the Database of State Incentives for Renewable Energy: www.dsireusa.org

Modulating Condensing Technology

The cost of fuel in some areas of the country has increased almost 40% in just one year! Versa-Hydro™ combined appliances provide a maximum payback on fuel savings. Savings can result in payback periods of less than 3 years. Depending on the age of your present equipment, our products could save you as much as 50% on your fuel bills.

Cost of Operation

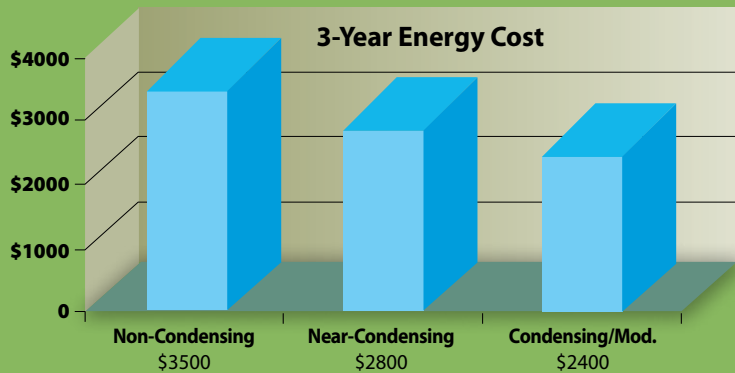

Space Savings

Imagine fitting a 55-gallon water heater, 135,000 BTU boiler, and buffer tank into a space as small as 34" x 53". The new Versa-Hydro™ does it!

FOOTPRINT COMPARISON

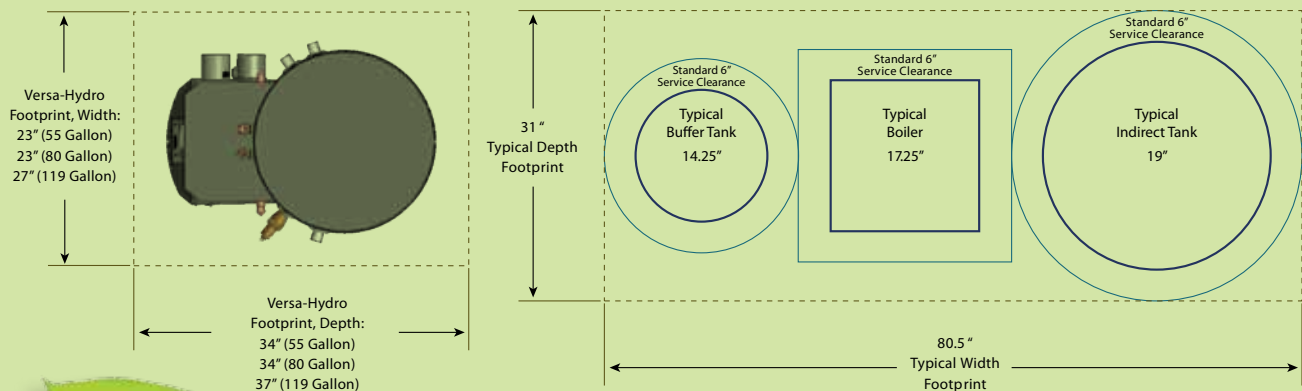

Installation Savings

Versa-Hydro™ – The One Appliance That Does it All!

The Versa-Hydro™ has just five easy piping connections – supply and return for heating, inlet and outlet for DHW and system feed – and you're done. It's cost-effective and free of clutter. There's no primary/secondary loop to install, no near boiler piping, no boiler/indirect electrical connections, and no isolation valves to install.

The Versa-Hydro™ reduces the clutter of multi-piece systems



Compare Total Costs

Boiler & Indirect

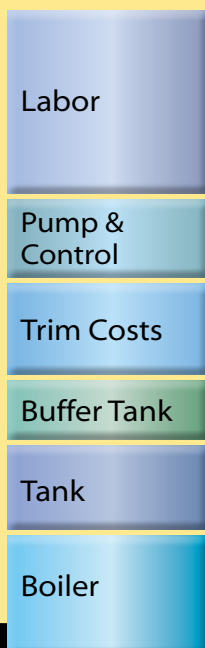

Versa-Hydro™



Versa-Hydro™ is the Clear Winner

No Primary/
Secondary Loop

No Near
Boiler Piping

No Boiler/Indirect
Electrical or Hydronic
Heating Connections

No Isolation Valves

Versa-Hydro™ Solar Solar Power

The First Solar Water & Space Heater with an Integrated Gas Fired Back-Up All in One High Efficiency Mod-Con Unit.

Versa-Hydro™ Solar Heater

The Versa-Hydro™ Solar is a truly revolutionary product that combines space heating and domestic hot water into one compact, high-efficiency mod-con unit. It is designed with a high-capacity internal solar heat exchanger for connection to solar panels or other renewable heat sources and with a highly-efficient 96% gas-fired back-up burner, all in one storage tank. The Versa-Hydro™ Solar will transfer energy from the sun on sunny days and still produce lots of hot water through the internal gas-fired back-up when the sun is not shining. Designed with advanced technology, the Versa-Hydro™ family of products optimizes efficiency and operating reliability.

**Stop
Paying for
Your Heat:
Harness
the Power
of the
Sun**

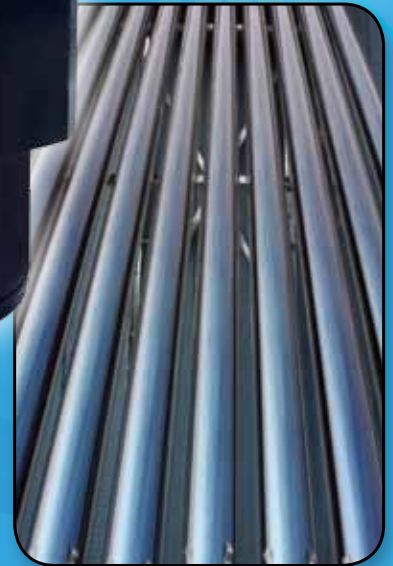
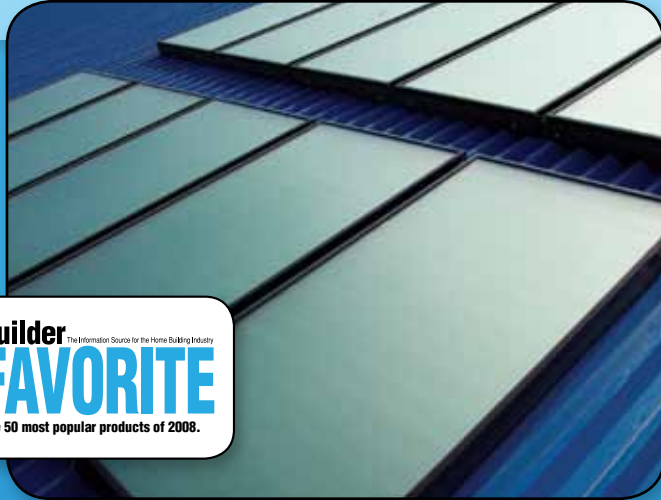

Easy to Set-Up! Easy to Use!

Controls

Tanks



Line Sets



Panels



**Everything
for a
Complete
Solar System**

Versa-Hydro™ Solar

GO GREEN

WHY SOLAR?

Because Solar Heating Pays Off For You

- Saves you money by cutting your electricity or gas use.
- Provides 50 to 75% of your home hot water needs.
- Diminishes CO₂ gasses that pollute our air.
- Adds value to the resale of your home or business.
- Provides energy savings.
- Provides radiant heating for your home or business.

Because We Care

Each solar panel eliminates tons of carbon dioxide from being released into the atmosphere. It would take the planting of more than 40 trees to recoup that much CO₂.

Because Solar Pays

Collecting and using solar energy reduces fuel consumption, be it electricity or natural gas, by 15,000 cubic feet of natural gas or 4,400 kwh, based on 40,000 BTU per day for each solar panel. (Consult local utility rates for your area.)

Helpful Rebate Links:

www.energystar.gov

www.dsireusa.org

www.aceee.org

Because Rebates Lower the Costs

\$ Federal Tax Incentives

\$ State Rebates & Incentives

\$ Utility Rebates & Incentives

\$ Local City or Municipality Rebates & Incentives

**KEEP
A TON OF
CARBON
DIOXIDE
OUT OF
THE AIR
EVERY YEAR!**



Versa-Hydro™

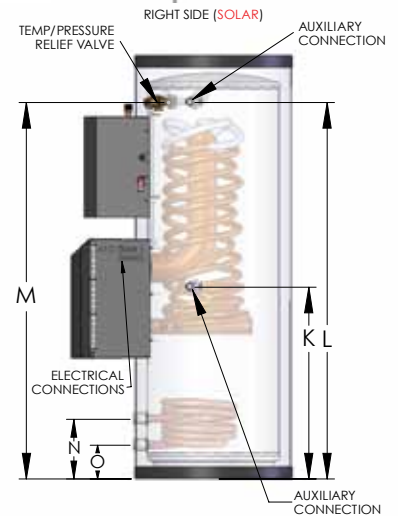
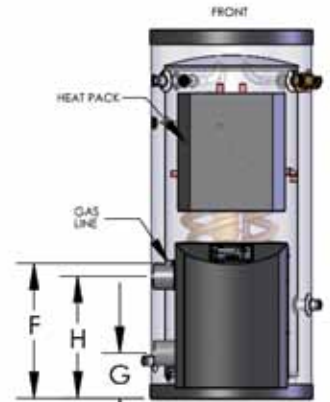
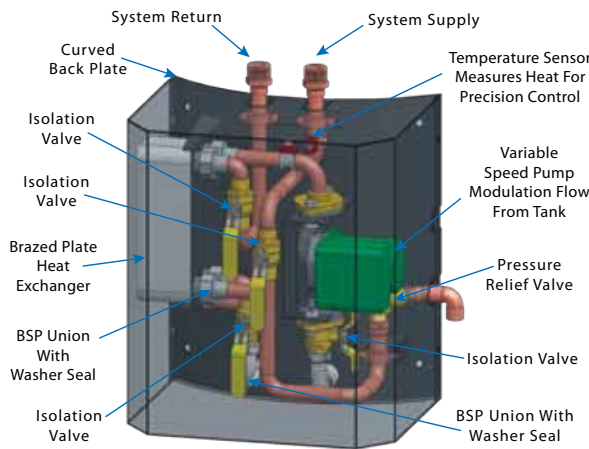
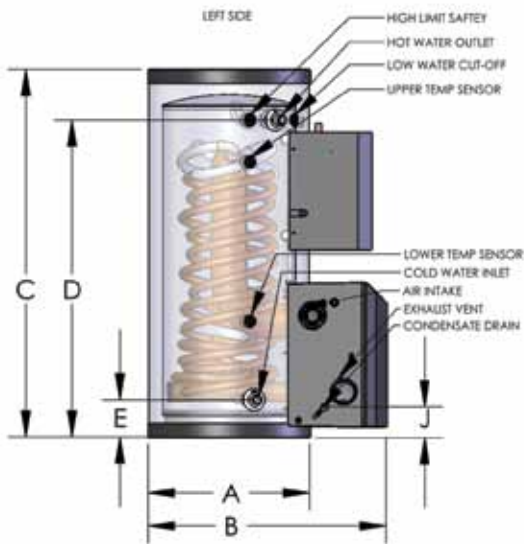

VERSA-HYDRO WATER HEATER DIMENSIONS													
MODEL #*	GALLONS	A	B	C	D	E	F	G	H	J	K	L	M
PHE130-55 / PHE199-55	55	23"	34"	53"	46"	5½"	19½"	7-3/8"	14½"	5"	14"	46"	46"
PHE130-80 / PHE199-80	80	23"	34"	72"	61"	5¼"	20½"	8-3/8"	15½"	6"	13"	61"	64½"
PHE130-119 / PHE199-119	119	27"	37"	74"	65¾"	7½"	20½"	8-3/8"	15½"	6"	14¼"	65¾"	66½"

VERSA-HYDRO SOLAR WATER HEATER DIMENSIONS															
MODEL #*	GALLONS	A	B	C	D	E	F	G	H	J	K	L	M	N	O
PHE130-80S / PHE199-80S*	80	23"	34"	72"	61"	5¼"	38½"	26"	37"	24"	31¼"	64½"	64½"	10¼"	10¼"
PHE130-119S / PHE199-119S*	119	27"	37"	74"	65¾"	7½"	38½"	26"	37"	24"	33"	64½"	64½"	5¾"	5¾"

*NHX (No Heat Exchanger) Version of the Versa-Hydro is available.

VERSA-HYDRO WATER HEATER SPECIFICATIONS											
MODEL #*	GALLONS	BTU'S	SPACE HEATING MODULE BTU'S	AIR INTAKE/ EXHAUST VENT SIZE	MAXIMUM SPACE HEATER TEMP.	WATER INLET/ OUTLET SIZE	AUX. CONN.	GAS LINE CONN.	SYSTEM RELIEF PIPE SIZE	SHIPPING WEIGHT	
PHE130-55 / PHE199-55	55	130,000	100,000	2"	160°	1" NPT	1"	3/4"	3/4"	205 LBS.	
		199,000	135,000	3"							
PHE130-80 / PHE199-80	80	130,000	100,000	2"	160°	1" NPT	1"	3/4"	3/4"	265 LBS.	
		199,000	135,000	3"							
PHE130-119 / PHE199-119	119	130,000	100,000	2"	160°	1" NPT	1"	3/4"	3/4"	435 LBS.	
		199,000	135,000	3"							

VERSA-HYDRO SOLAR WATER HEATER SPECIFICATIONS											
MODEL #*	GALLONS	BTU'S	SPACE HEATING MODULE BTU'S	AIR INTAKE/ EXHAUST VENT SIZE	MAXIMUM SPACE HEATER TEMP.	WATER INLET/ OUTLET SIZE	AUX. CONN.	GAS LINE CONN.	SYSTEM RELIEF PIPE SIZE	SHIPPING WEIGHT	
PHE130-80S / PHE199-80S	80	130,000	100,000	2"	160°	1" NPT	1"	3/4"	3/4"	275 LBS.	
		199,000	135,000	3"							
PHE130-119S / PHE199-119S	119	130,000	100,000	2"	160°	1" NPT	1"	3/4"	3/4"	445 LBS.	
		199,000	135,000	3"							

Model	1st Hr. Rating	Recovery @ 100° F. Rise
PHE 130-55	205 Gal	148 GPH
PHE 130-80	227 Gal	150 GPH
PHE 130-119	257 Gal	152 GPH
PHE 199-55	295 Gal	229 GPH
PHE 199-80	314 Gal	229 GPH
PHE 199-119	335 Gal	230 GPH

* No suffix denotes natural gas and suffix "LP" denotes propane gas
 In keeping with its policy of continuous product improvement, HTP reserves the right to make changes without notice.



12 Year Limited Warranty



MKTLIT-03 © 04 / 2011 HTP