



SUPERstor

MARINE WATER HEATERS

INSTALLATION

Heater must be installed in accordance with local codes. When possible, locate the heater near a floor drain for convenient flushing and draining. Provisions should be made so that, in the event the water heater or its fittings were to leak, the resulting flow of water will not cause damage to the surroundings or other critical areas of the boat/structure. The heater and water lines should be protected from freezing temperatures. Refer to page 4, for typical installations. The mounting tabs should be securely mounted to a solid flat deck or floor with a minimum of all four tabs provided. **Supplementary bracing should always be used.** If it is necessary to fasten with wood screws, they must be sized to support the water heater during movement. If this installation is subject to heavy rocking and/or banging, supplementary bracing is required. When installing water heater, consider the openings for cold water and drains; temperature and pressure relief valve; hot water outlet; electrical connection; and heat exchanger connections.

TO CONNECT HEATER

Use unions on the hot and cold water connections and the relief valve discharge line, so that the heater may be easily disconnected for servicing when necessary.

1. Connect cold water supply line to pipe connection marked “**COLD**” near bottom of heater (See fig. 1)
2. Install a shut-off valve and a drain valve, **not supplied**, in the cold water line near heater. A check valve or any other no return device must be installed to prevent hot water back flow into the cold water tank and cold water lines.

NOTE: The drain valve must be installed between the check valve and water heater to enable draining when necessary.

3. Connect hot water line to pipe connection to outlet marked “**HOT**”, on side near the top of the heater. (See fig. 1)

⚠ DANGER



Water temperature over 125 degrees F. can cause severe burns instantly, or death from scalds. Children, disabled, and elderly are at highest risk of being scalded. See instruction manual before setting temperature at water heater. Feel water before bathing or showering! Temperature limiting valves are available. See instruction manual.



⚠ CAUTION

T & P valve is provided near the top of the heater. This valve provides protection against excessive pressures and temperatures in this water heater. When replacing for whatever reason, temperature-and-pressure protective equipment must meet local codes; but not less than a combination temperature-and-pressure-relief valve, certified as meeting the requirements for Relief Valves and Automatic Gas Shut-off Devices for Hot Water Supply Systems, ANSI Z21.22, by a nationally recognized testing laboratory that maintains periodic inspection of production of listed equipment or materials. The discharge opening must not come in contact with any live electrical part or be locked or reduced in size under any circumstances. Pipe the discharge outlet of relief valve to suitable open drain using pipe full size of relief valve outlet. The end of the discharge line should not be concealed or threaded and should be protected from freezing.

TO FILL HEATER

Make certain field installed drain valve is completely closed. Open Shut-off valve in cold water supply line. Open hot water faucet(s) to allow air to vent from the heater and piping. Allow sufficient time for the heater to completely fill with water, as indicated by a steady flow of water from the hot water faucet(s).

CAUTION

You must always vent air from the water heater when ever a new water supply hook-up is made. WARNING: TANK MUST BE FULL OF WATER BEFORE POWER IS TURNED ON! Heating element will be damaged if energized for even a short time while tank is dry.

WIRING INSTRUCTIONS

Heaters are completely factory wired to junction bracket inside jacket at lower front of heater. An opening with a knock-out for 1/2" electrical fitting is provided for field wiring connection. Heaters are equipped and wired for 120 volt A.C. Use a 15 AMP fuse or circuit breaker. The voltage requirement and wattage load for the heater is specified on the heater identification plate. Refer to wiring diagrams on back of the instruction sheet. Electrical installation should be made by a qualified licensed electrician. All wiring must conform to *local codes* or *National Electric Codes*. Equipment grounding can be accomplished by using approved conduit and fittings or other approved conductive material. A grounding wire is provided, on the junction bracket, in the event a separate grounding conductor must be used.

OPERATION

After water and electrical connections have been made and tank has been filled with water, turn on power to heater. The heater is now in operation.

THERMOSTAT ADJUSTMENT

Thermostat is set 119° F. This temperature is satisfactory for average use. If adjustment is necessary, **TURN OFF POWER TO HEATER**, remove thermostat-element cover panel and insulation. The thermostat protective cover should not be removed. Set temperature indicator to desired temperature, replace insulation and thermostat-element cover panel. Turn on power to heater.

COMBINATION "THERMOSTAT AND HIGH LIMIT CONTROL (ECO)"

This heater is equipped with a combination "Thermostat - High Limit Control (ECO)" which is located above the heating element. If for any reason the water temperature becomes excessively high, the "High Limit Control (ECO)" breaks the circuit to the heating element. Once the switch opens, it must be reset manually. However, **THE CAUSE OF THE OVER TEMPERATURE CONDITION MUST BE CORRECTED FIRST**. To reset "High Limit Control (ECO)" - **TURN OFF POWER TO HEATER**, remove thermostat-element cover panel and insulation. The thermostat protective cover should not be removed. Press red "RESET" button toward tank. Replace insulation and cover panel before turning on power to heater.

SERVICE MAINTENANCE

It is recommended that a few quarts of water be drained from the heater every other month or few weeks. This will flush sediment deposits from the bottom of the heater and lengthen the heater's service life. **Turn off power to heater during flushing operation**, so the element will not be damaged. To flush heater's tank, attach a hose to field installed drain valve in the cold water supply line; close supply line shut-off valve; open drain line valve and hot water faucet(s), to vent heater while draining. Direct the flow of water to a drain where it will not cause damage. After flushing operation is completed, **make certain heater is completely full of water before restoring power to heater**. When heater is not used during winter months, turn off power to heater and drain water from heater and piping to prevent freezing.

HEAT EXCHANGER

The heat exchanger is connected to the engine cooling line or radiator line by connecting an adapter or simply by just connecting with a rubber hose. Assure that you have sufficient flow as to the manufacturer's recommendations of the engine, and that you are on the hot or outlet side of the engine. The hot water heat exchanger will handle 3 GPM, maximum. If engine requires more than 3 GPM, a bypass must be used. (See Fig. 3) Two 1/2" N.P.T. female brass fittings are on the tank to hook up to the heat exchanger for connection to engine coolant. Because of the diversity of marine cooling configurations, it is not possible to provide universal installation instructions; the installer **MUST** follow engine manufacturer's recommendations. **FIGURE 3 IS INTENDED ONLY AS A GENERAL GUIDELINE TO SHOW HOW A PORTION OF THE ENGINE COOLANT MAY BE DIVERTED TO THE OPTIONAL HEAT EXCHANGER.**

NOTE: Some marine engines run at higher temperatures than the range of the pressure relief valve on the water heater. For use with these engines, an alternate location for source water will have to be selected.

DIMENSIONS							
MODEL	"A"	"B"	"C"	"D"	"E"	"F"	INLET/OUTLET
SS-6M	14-1/4"	16-1/2"	9-1/4"	3-1/2"	4-1/2"	9-1/4"	1/2" NIPPLE
SS-12M	16-1/4"	19"	12-1/4"	2"	3-1/2"	12-1/4"	1/2" NIPPLE
SS-20M	19-1/4"	27"	22"	4-3/4"	4-3/4"	22"	3/4" NIPPLE
EV-6M	14-1/4"	16-1/2"	9-1/4"	N/A	4-1/2"	9-1/4"	1/2" NIPPLE
EV-12M	16-1/4"	19"	12-1/4"	N/A	3-1/2"	12-1/4"	1/2" NIPPLE
EV-20M	19-1/4"	27"	22"	N/A	4-3/4"	22"	3/4" NIPPLE

SHUT-OFF VALVE, DRAIN VALVE, CHECK VALVE SHOULD BE INSTALLED IN THE COLD WATER LINE.

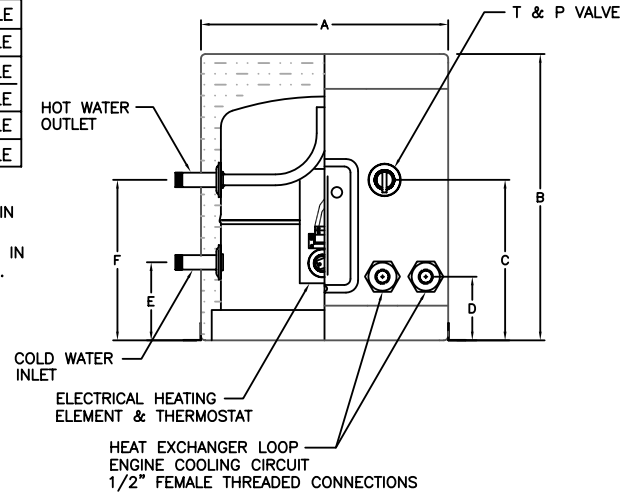

Figure 1

⚠ CAUTION

HEATER MUST BE FILLED WITH WATER BEFORE POWER IS TURNED ON!

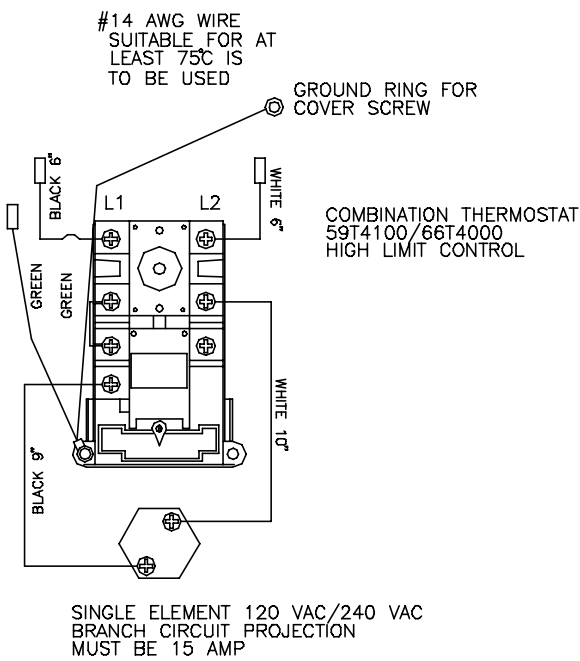
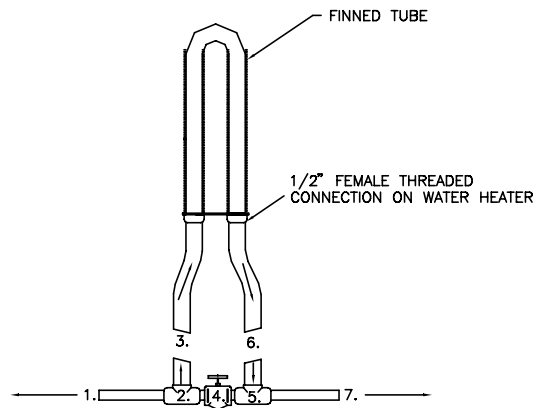

Figure 2

HEAT EXCHANGER INSTALLATION



LEGEND:

1. HOTTEST WATER FROM ENGINE (FULL FLOW).
2. PIPE TEE: FULL FLOW ON RUN, 3/4" NPT ON BRANCH.
3. HOSE TO HOT WATER HEAT EXCHANGER.
4. GATE VALVE SIZED TO PERMIT FULL FLOW OF COOLANT.
5. PIPE TEE: FULL FLOW ON RUN, 3/4" NPT ON BRANCH.
6. HOSE FROM HOT WATER HEAT EXCHANGER.
7. FULL FLOW RETURN TO ENGINE COOLING SYSTEM.

Figure 3

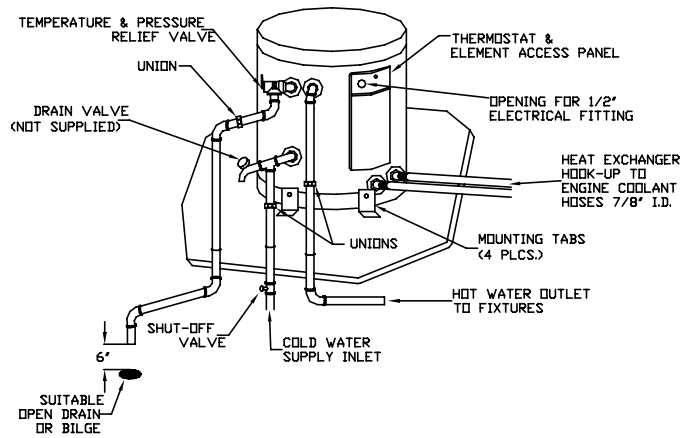

Figure 4

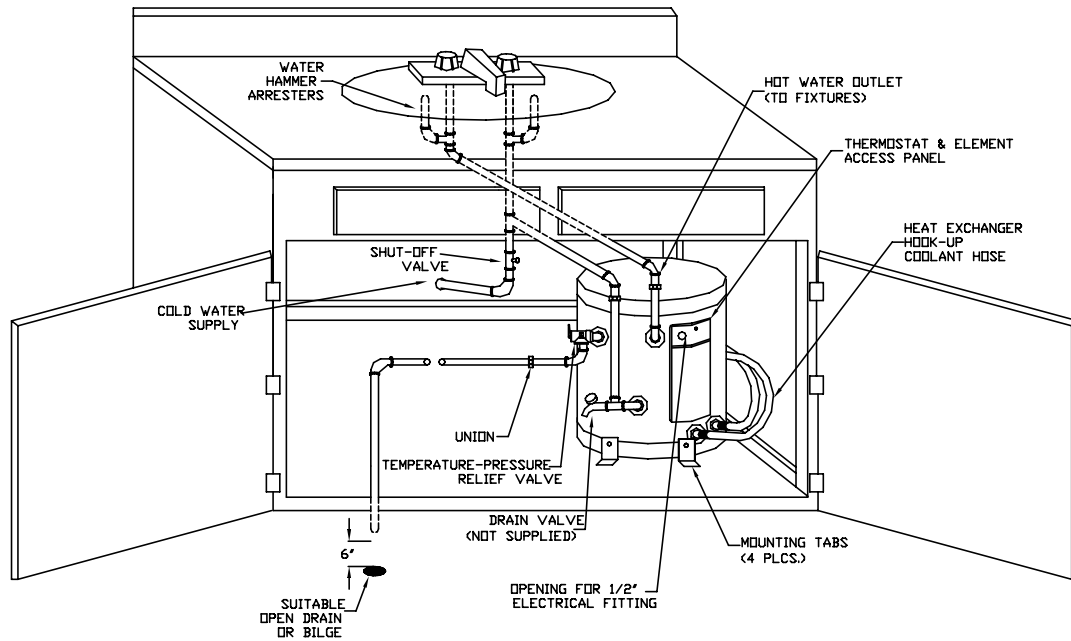

Figure 5

HEAT TRANSFER PRODUCTS, INC.

120 Braley Road • P.O. Box 429 • East Freetown • MA 02717 • (508) 763-8071 • 1-800-323-9651 (Outside MA) • Fax (508) 763-3769