



Elite Fire Tube Wall Mounted Combined Appliance Submittal Sheet

JOB NAME:

LOCATION:

ARCH. / ENGR.:

WHOLESALE:

MECH. CONTRACTOR:

MODEL NUMBER:

BTU/HR INPUT LOW - HIGH FIRE:

TYPE OF GAS:

NOTES:

Heat Exchanger

- All 316L Stainless Steel ASME “H” Stamped Construction
- National Board listed
- Low pressure drop, gasketless, vertical tube combustion heat exchanger design – provides maintenance-free operation on internal buildup of material inside the combustion chamber
- High fin aluminum inner insert provides superior heat transfer to transmit energy more efficiently
- 30 PSI Relief Valve
- Internal indirect storage tank constructed with 316L stainless steel

Combustion System

- 140W Model have modulating burner turn down 5 to 1
- 199W Model have modulating burner turn down up to 10 to 1
- Models with installed optional large external pump
- Up to 95% AFUE
- High Grade Ceramic Fiber Burner Design
- Spark Ignition
- Models Available for Natural or LP Gas
- Optical Flame monitoring

Integrated Control System

- Digital operating control and display to program and monitor boiler operation
- Programmable settings: Outdoor Reset Curve – DHW Supply Set Point – Step Sequence for delayed response for smart zones – Boost Response – Internal Storage Tank Setpoint Temperature
- Field Connection Board – Line voltage terminal strip with 120 VAC / 60 Hertz power / low voltage terminal strip with multiple contacts
- 0-10 VDC input
- Boiler output regulation (Adjustment of boiler output down to 50 percent of rated capacity)
- Low water protection device
- Freeze protection

Additional Features

- Superior condensate collection system with overflow protection switch
- Additional flow restrictor to increase flow rate on domestic hot water circuit
- Vents in Plastic PVC - CPVC - Stainless Steel – ULC S636 flexible polypropylene vent liner (chimney lining only)
- Vents up to 100 combined equivalent feet – 3 inch venting, and 50 combined equivalent feet – 2 inch venting
- 10 Year Limited Warranty
- Manual reset high temperature limit
- Included wall mount bracket
- Built-in low water cutoff
- Low NOx emissions – SCAQMD Certified
- Lead Free Compliant, as required by the Safe Drinking Water Act, Section 1417

Optional Components

- 3” Polypro Flex Vent Kit (8400P-001)
- 3” (80mm) PP Concentric Vent Kit (KGAVT0601CVT)
- 3” Stainless Steel Termination Vent Kit (V1000)
- 4” Stainless Steel Termination Vent Kit (V2000)
- Condensate Neutralizer (7450P-212)
- 3/4” Tankless DHW Isolation Valves (7850P-090)

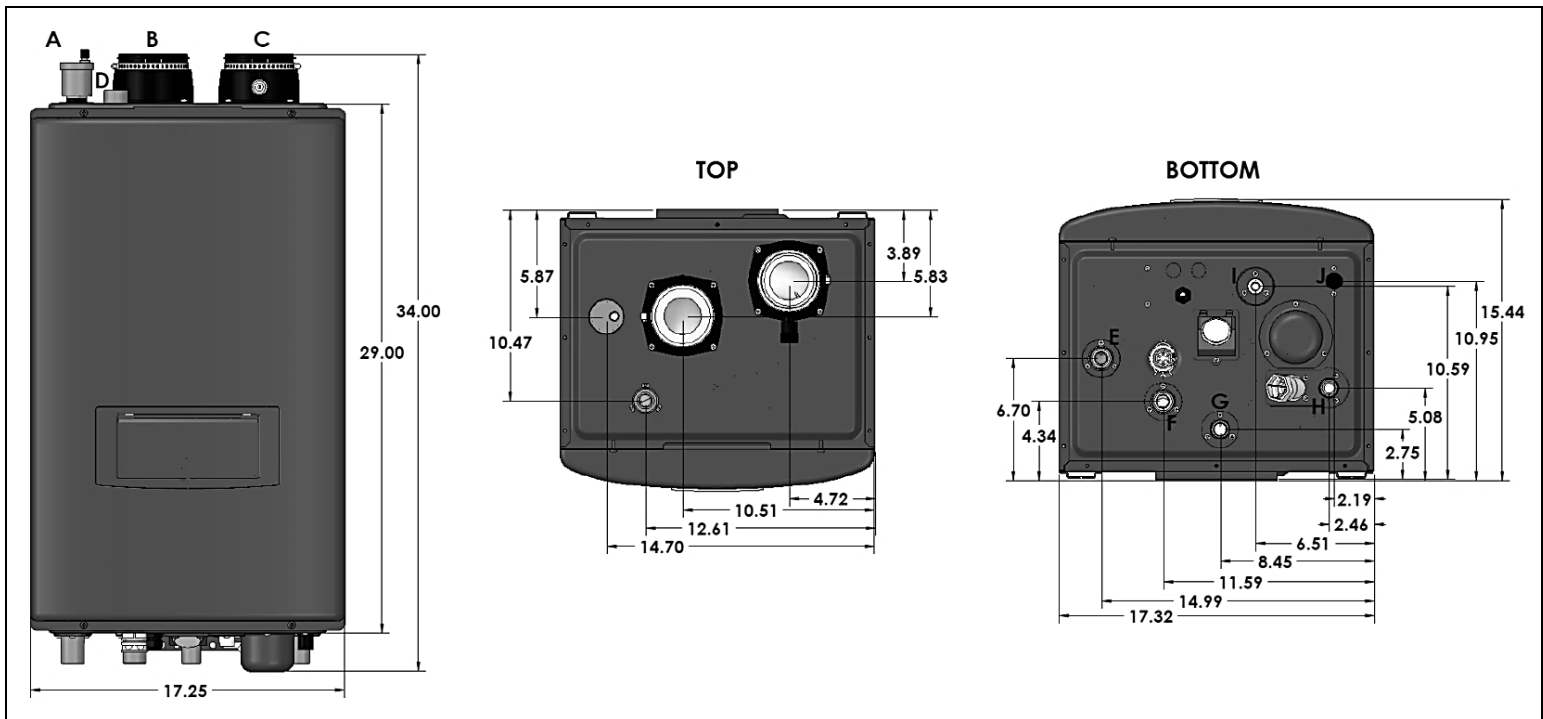

Figure 1 – 140W Specifications and Dimensions

	DESCRIPTION	DIAMETER (ALL NPTM)
A	Automatic Air Vent	-
B	Intake Pipe Connection	3"
C	Exhaust Vent Connection	3"
D	Relief Valve Adapter	¾" NPT
E	CH Supply Adapter	1" NPT
F	CH Return Adapter	1" NPT
G	DHW Outlet Adapter	¾" NPT
H	DHW Inlet Adapter	¾" NPT
I	Gas Connection Adapter	½" NPT (1/2" X ¾" Bell Coupling Provided to Upsize Gas Line)
J	Condensate Adapter	-

Table 1 – 140W Adapter Specifications

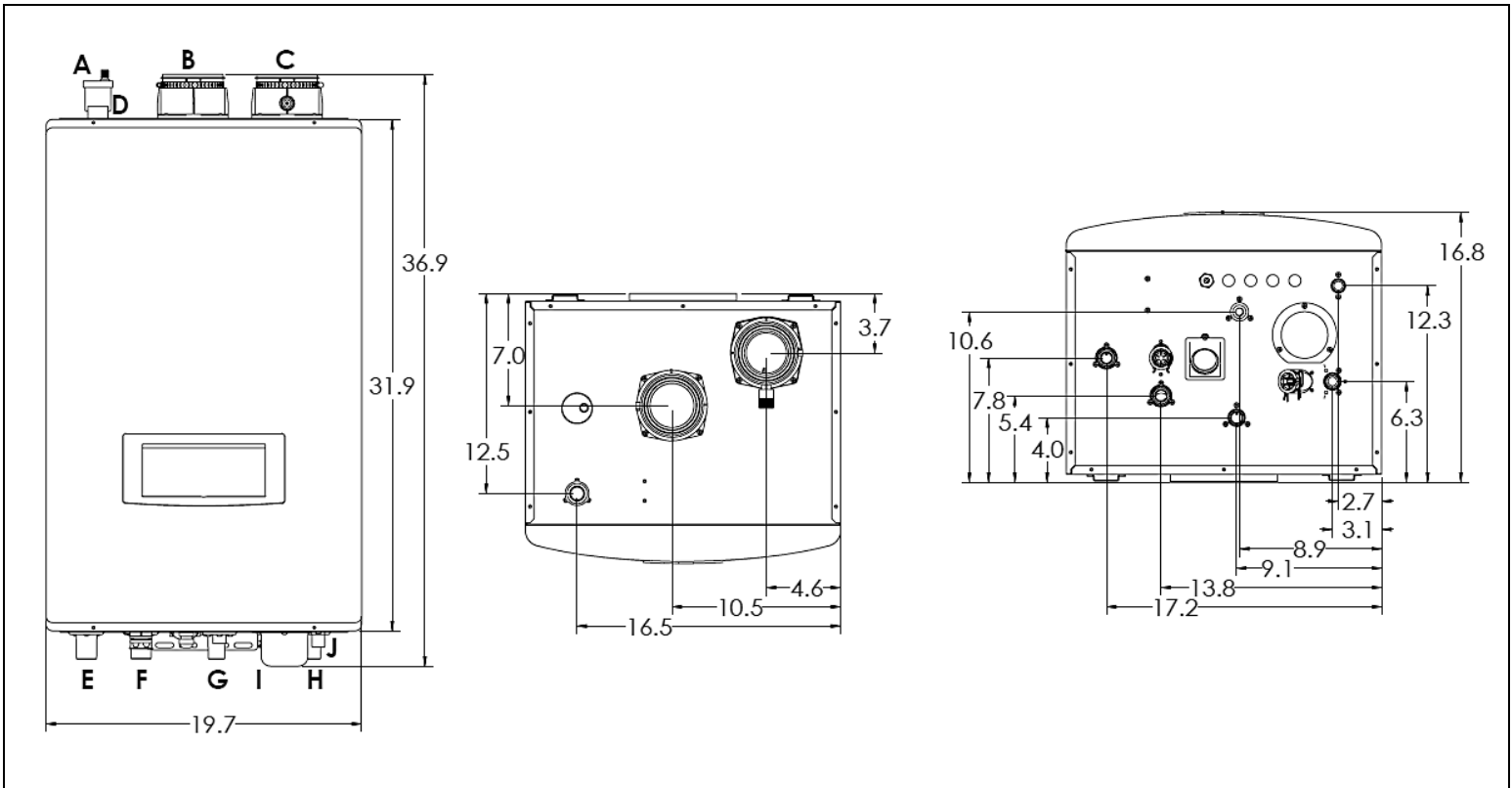

Figure 2 - 199W Specifications and Dimensions

	DESCRIPTION	DIAMETER (ALL NPTM)
A	Automatic Air Vent	-
B	Intake Pipe Connection	3"
C	Exhaust Vent Connection	3"
D	Relief Valve Adapter	¾" NPT
E	CH Supply Adapter	1" NPT
F	CH Return Adapter	1" NPT
G	DHW Outlet Adapter	¾" NPT
H	DHW Inlet Adapter	¾" NPT
I	Gas Connection Adapter	½" NPT (1/2" X ¾" Bell Coupling Provided to Upsize Gas Line)
J	Condensate Adapter	-

Table 2 - 199W Adapter Specifications

MODEL		140W	199W
Installation		Indoor, Wall Mount, Fully Condensing	
Minimum / Maximum Input (Btu/Hr)	Central Heating (CH)	28,000 / 140,000	19,900 / 140,000*
	Domestic Hot Water (DHW)		19,900 / 199,000*
AFUE		95%	
Hot Water Capacity	35°F Rise	7.1 Gal	9.9 GPM
	45°F Rise	5.5 Gal	7.7 GPM
	77°F Rise	3.2 Gal	4.8 GPM
Flue System		Sealed Combustion Direct Vent, Power Vent	
Combined Vent Length		2" (50 feet), 3" (100 feet)	
Shipping Weight (lbs est.)		110	120
Orifice Size	NG	0.255" (6.5 mm)	0.327" (8.3mm)
	LP	0.19" (4.85 mm)	0.244" (6.2mm)
Gas Supply Pressure	NG	3.5" to 14" WC	
	LP		
Manifold Pressure	Min (2" / 3" Vent)	NG/LP: 0" WC	NG/LP: -0.015" WC
	Max (2" / 3" Vent)	NG/LP: -0.22" WC	NG/LP: -0.134"WC / -0.173"WC
Power Supply	Main Supply	120V 60 Hz / 6A	
	Maximum Power Consumption	160W	
Ignition System		Direct Electronic Ignition / Automatic Flame Sensing	
Burner System		Single Orifice Premixed Fuel Modulation Ceramic Fiber Infrared	
Gas Valve System		Combination Modulating (Current Proportional)	
Internal Pipe Material		Copper	
Dimensions		W 17.25" – H 34" – D 15.5"	W 19.7" – H 37" – 16.8"
Minimum Flow Rate		0.5 GPM	
Internal Storage Tank Water Capacity (DHW)		1 Gallon	1.5 Gallons
Heat Exchanger Capacity		4 Gallons	3.5 Gallons
Total Water Capacity		5 Gallons	
Main Controller / Control Panel		NGTX-900C / P-920C_CB-HTP	
CH Pressure		Min 12 PSI - Max 30 PSI	
DHW Pressure		Max 150 PSI	
Connection Sizes	DHW Inlet / Hot Water Outlet	¾" NPT	
	CH Supply / Return	1" NPT	
	Gas Inlet	½" NPT (1/2" X ¾" Bell Coupling Provided to Upsize Gas Line)	¾" NPT
Materials	Cabinet	Cold Rolled Carbon Steel	
	Heat Exchanger	Primary Heat Exchanger: Stainless Steel Storage Tank: Stainless Steel	
Safety Devices		Optical Flame Sensor, Burner Plate High Limit (392°F), Water Temperature High Limit Sensor (200°F), Freeze Protection (Three Stage Operation - Activates at 46°F – See Freeze Protection in Installer Menu for Details), Exhaust Temperature High Limit Sensor (190°F), Blocked Flue Switch, Condensate Switch, Built-In Low Water Cut-Off Probe	

Table 3 – Technical Specifications – NOTE: 199W Models Offer a Maximum BTU/Hr Input of 140,000 as Shipped. Maximum BTU/Hr can be increased up to 199,000 BTU/Hr with a Larger External Pump Installed in the Primary Loop

NOTE: HTP reserves the right to make product changes or updates without notice and will not be held liable for typographical errors in literature.