

Installing, Operating & Maintaining MUNCHKIN HIGH EFFICIENCY HEATER

 **WARNING:**

If the information in this manual is not followed exactly, a fire or explosion may result causing property damage, personal injury or loss of life.

Do not store or use gasoline or other flammable vapors and liquids in the vicinity of this or any other appliance.

WHAT TO DO IF YOU SMELL GAS

Do not try to light any appliance.

Do not touch any electrical switch: do not use any phone in your building.

Immediately call your gas supplier from a neighbor's phone.

Follow the gas supplier's instructions.

If you cannot reach your gas supplier, call the fire department. Installation and service must be performed by a qualified installer, service agency or the gas supplier.



 **WARNING:**

This manual must only be used by a qualified heating installer / service technician. Failure to comply could result in severe personal injury, death or substantial property damage. It is also important to keep these Instructions with the appliance.

TABLE OF CONTENTS

PART 1

GENERAL INFORMATION

1-A. HOW IT OPERATES.....	1
1-B. LOCATION	2
1-C. PRESSURE RELIEF VALVE.....	2

PART 2

2-A. ELECTRICAL CONNECTION	2
----------------------------------	---

PART 3

3-A. GAS CONNECTION	3
3-B. GAS PIPING	3
3-C. GAS TABLE	3

PART 4

VENTING

4-A. ALL MODELS 3 VENTED.....	4
4-B. FOR LONGER VENT LENGTHS	5
4-C. VENTING TABLE	5-6
4-D. CLEANER/CEMENT	6
4-E. CONDENSATE.....	6
4-F. VENTING TABLES	7

PART 5

5-A. HYDRONIC HEAT PIPING.....	8
5-B. FILL AND PURGE HEATING SYSTEM.....	8

PART 6

BOILER START UP

6-A. COMMON VENT TEST	9
6-B. ITEMS TO BE CHECKED BEFORE LIGHTING THE MUNCHKIN	10
6-C. LIGHTING INSTRUCTIONS	11

PART 7

SERVICING

7-A. SEQUENCE OF OPERATION	12
7-B. ADJUSTMENT SET POINTS AND DIFFERENTIAL SETTINGS	12
7-C. MUNCHKIN BOILER FAULT LED CODE	13
7-D. FAULT CONDITIONS.....	13-14

PART 8

8-A. MAINTENANCE PROCEDURES	15
8-B. BEFORE EACH HEATING SEASON	15
8-C. COMPONENT DIAGRAM.....	16



WARNINGS

CAUTIONS

THIS UNIT IS FOR CATEGORY IV VENTING - 2 PIPE ONLY. THIS IS A SEALED COMBUSTION APPLIANCE.

THIS HEATER INSTALLATION MUST CONFORM TO THE LATEST EDITION OF THE "NATIONAL FUEL GAS CODE" ANSI Z223.1 STATE AND LOCAL CODES MIGHT ALSO APPLY TO INSTALLATION.

WHERE REQUIRED BY THE AUTHORITY HAVING JURISDICTION, THE INSTALLATION MUST CONFORM TO THE STANDARDS FOR CONTROLS AND SAFETY DEVICES FOR AUTOMATICALLY FIRED BOILERS, ANSI/ASME BOILER AND PRESSURE VESSEL CODE, Section IV.

THE HEATER, GAS PIPING, WATER PIPING, VENTING AND ELECTRICAL MUST BE INSTALLED BY TRAINED & QUALIFIED PERSONNEL FAMILIAR WITH INSTALLATION PRACTICES AND LOCAL CODE AND LICENSING REQUIREMENTS.

IF THE INFORMATION IN THESE INSTRUCTIONS ARE NOT FOLLOWED EXACTLY, A FIRE OR EXPLOSION MAY RESULT; CAUSING PROPERTY DAMAGE, PERSONAL INJURY, OR DEATH.

DO NOT STORE OR USE GASOLINE OR OTHER FLAMMABLE VAPORS AND LIQUIDS IN THE VICINITY OF THIS OR ANY OTHER APPLIANCE;

WHAT TO DO IF YOU SMELL GAS:

Do not try to light any appliance.

Do not touch any electrical switch: do not use any phone in your building.

Immediately call your gas supplier from a neighbors' phone.

Follow the gas suppliers' instructions.

If you cannot reach your gas supplier, call the fire department.

Installation and service must be performed by a qualified installer: service agency or the gas supplier .

PART 1

GENERAL INFORMATION

1-A. HOW IT OPERATES

When the room thermostat calls for heat, the Munchkin control board will start the pump and start to monitor the return temperature of the system before the heater will begin to heat the water. Once the controller has sensed a drop in the return water temperature below the temperature set point minus the differential set point, the boiler will start to heat the water. This eliminates the Munchkin starting every time the thermostat calls for heat. This feature keeps the system from short cycling.

Once the system has sensed the temperature difference, the Munchkin will activate the blower motor for 5 seconds to pre-purge the system before starting the Munchkin. The Munchkin controller will now start to modulate the pre-mix burner based on analyzing the turn temperature, supply water temperature and the set point temperature. By compiling this information, the controller utilizes an algorithm to fully adjust the firing rate while maintaining the desired output temperature. The pre-mix burner fans have a low-voltage direct current drive motor with a pulse relay counting. This system allows precise control over the fan speed and combustion air volumes. Coupled with the Honeywell gas valve and the Venturi system which are set to provide a one-to-one ratio of precisely measured volumes of fuel to air an accurate and instant burner output is achieved. This keeps the Munchkin running at the **highest efficiency**.

When the thermostat is satisfied, the Munchkin will then go through a 4 second post-purge cycle before shutting off. Every Munchkin heater is equipped with an indicator light which will pulse constantly in normal operation. When a problem occurs, the indicator light will blink slowly to indicate the heater fault.

1-B. LOCATION

**⚠ WARNING:
THE MUNCHKIN MUST BE SET ON A LEVEL SURFACE SO
CONDENSATION DOES NOT BACK UP INSIDE BOILER!**

The Munchkin is designed for Installation on combustible flooring, in alcoves, basements, closets, utility rooms. The Munchkin shall be installed so that the gas ignition system components are protected from water. This includes all related piping and components.

Choose a location for your Munchkin, centralized to the piping system, along with consideration to vent pipe length. The length of vent pipe increases the firing rate of the Munchkin decreases. You must also locate the Munchkin where it will not be exposed to freezing temperatures. Additionally, you will need to place the heater so that the controls, inlet/outlet, and gas valve are easily accessed. This Munchkin must not be installed outdoors, for it is certified as an indoor appliance only and must be kept vertical and on a level surface. Also, care must be exercised when choosing the location of this appliance; where leakage from the relief valve and from related piping will not result in damage to the surrounding areas or to the lower floors of the building. **A heater should always be located in an area with a floor drain or installed in a suitable drain pan.** Proper clearance must be provided around the Munchkin as follows: Sides, bottom, top, and back are 0" (zero clearance). Venting is also zero clearance. The front of the appliance needs 24" of clearance for service minimum. It must have a non-rated or combustible door or access panel and should have a minimum clearance of 24" front, 15" top, 6" right side and 10" to the left side. **Under no circumstances, shall Heat Transfer Products Inc. be held liable for any such water damage whatsoever. This heater must not be located near flammable liquids such as gasoline, adhesives, solvents, paint thinners, butane, liquefied propane, etc., the controls of this appliance could ignite those vapors, causing an explosion.**

1-C. PRESSURE RELIEF VALVE

A pressure relief valve is installed into the front right side manifold we recommend a WATTS "M 335 MI valve or equivalent and meets the requirements of ANSI/ASME Section IV for heating boilers. A " pipe must be directed to a floor drain or suitable location within 6" of drain or floor. Protect from freezing, do not plug or cap pressure relief valve. Serious explosion causing property damage and or loss of life could result. Under no circumstances should the relief valve be eliminated, capped or plugged.

PART 2

SERVICING - ⚠ WARNING - CAUTION
Before servicing let the munchkin cool down! Shut off electrical and gas supply.
Failure to follow warning could result in severe burn, electrical shock, gas leakage, fire or explosion.

2-A. ELECTRICAL CONNECTION

The electrical connection for the Munchkin is on the left side of the unit. There is a %" knockout location for electrical connection. All electrical wiring must be performed by a qualified licensed electrician in accordance with National Electrical Code, or to the applicable local codes and standards. For your convenience we have labeled all the wire which needs to be connected to operate the Munchkin. Caution: Do not remove labels on wires prior to disconnection. The electrical requirements are for standard 120 volts, 60 Hz 10 amp service. This unit must be wired with #14 awg and fused for no more than 15 amps. **It is of extreme importance that this unit be properly grounded.** There are two ground points in the electrical compartment that must be connected to the building ground system. Connect the building to the green ground screw and the green ground wire. **It is very important that the building system ground is inspected by a qualified electrician prior to making this connection.**

The black wire is the hot lead and white wire is the neutral lead. Once all connections have been made the electrical access may be closed. It is very important that the electrical power is not turned on at this time! A green LED is provided on the main control board. This LED must be illuminated when the Munchkin is turned on for proper operation.

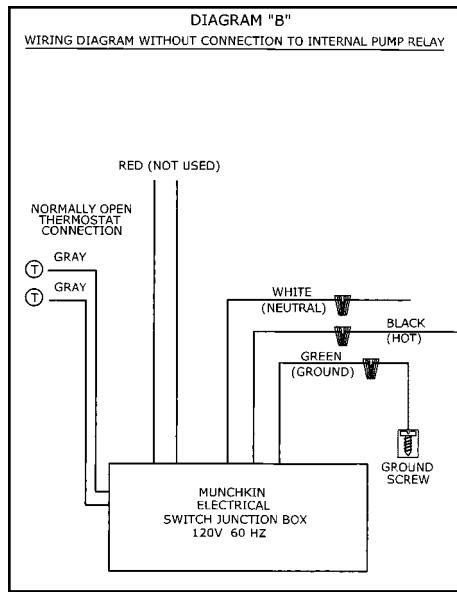
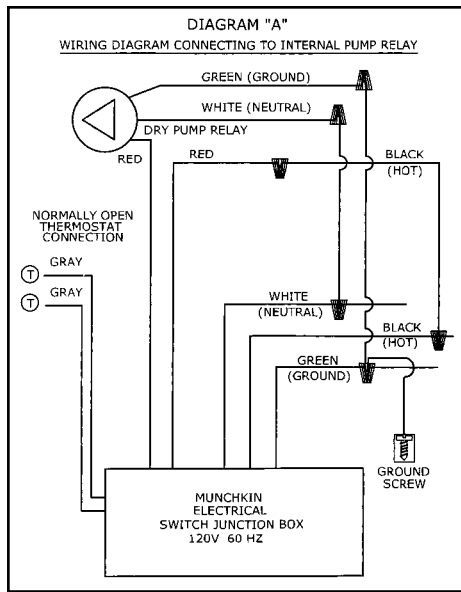

PART 3

3-A. GAS CONNECTION

The gas supply shall have a maximum inlet pressure of less than 14" water column (350 mm), ½ pound pressure (3.4 kPa), and a minimum of 7" water column. The entire piping system, gas meter, and regulator must be sized properly to prevent pressure drop greater than 0.5" as stated in the National Fuel Gas Code. This information is listed on the rating plate. **It is very important that you are connected to the type of gas as noted on the rating plate.** "LP" for liquefied petroleum, or propane gas or, "Nat" natural or city gas. All gas connections must be approved by the local gas supplier, or utility in addition to the governing authority, prior to turning the gas supply on. The nipple provided is ½" and it is mandatory that a ½" to ¾" reducing bushing (provided) is used, threaded into the branch of a 1" tee, and a drip leg fabricated, as per the National Fuel Gas code. **You must ensure that the entire gas line to the connection at the Munchkin is no smaller than ½".** Once all the inspections have been performed, the piping must be leak tested. If the leak test requirement is a higher test pressure than the maximum inlet pressure, you must isolate the Munchkin from the gas line. In order to do this, you must shut the gas off following lighting instruction on page 11. Unscrew the threaded mounting flange which is located on the gas valve which will prevent high pressure which may damage the gas valve. In the event the gas valve is exposed to a pressure greater than ½ PSI, 14" water column, the gas valve must be replaced. **Never use an open flame (lit match, lighter) to check gas connections.**

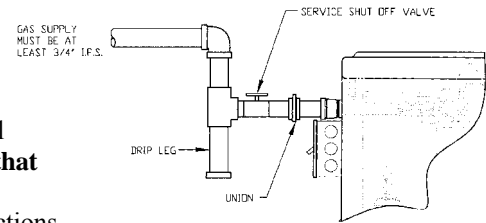

3-B. GAS PIPING

⚠ WARNING
Failure to follow all precautions could result in fire, explosion or death!

1. Run gas supply line in accordance with all applicable codes.
2. Locate and install manual shutoff valves in accordance with state and local requirements.

3-C. GAS TABLE

Refer to Table (1) to size the supply piping to minimize pressure drop between meter or regulator and unit. Maximum Capacity of Pipe in Cubic Feet of Gas per Hour for Gas Pressures of 0.5 psi or Less and a Pressure Drop of 0.3 Inch water Column

(TABLE 1) (Based on a 0.60 Specific Gravity Gas)

Nominal Iron Pipe Size (inches)	Internal Diameter (inches)	Length of Pipe (Feet)															BTU'S PER HOUR X 1,000		
		10	20	30	40	50	60	70	80	90	100	125	150	175	200				
3/4	.824	278	190	152	130	115	105	96	90	84	79	72	64	59	55	}			
1	1.049	520	350	285	245	215	195	180	170	160	150	130	120	110	100			}	
1 1/4	1.380	1,050	730	590	500	440	400	370	350	320	305	275	250	225	210				
1 1/2	1.610	1,600	1,100	890	760	670	610	560	530	490	460	410	380	350	320			}	

It is recommended that a soapy solution be used to detect leaks. Bubbles will appear on pipe to indicate a leak is present. The gas piping must be sized for the proper flow and length of pipe, to avoid pressure drop. Both the gas meter and the gas regulator must be properly sized for the total gas load. If you experience a pressure drop greater than 1" WC, the meter or regulator or gas line is undersized or in need of service. You can attach a meter to the incoming gas drip leg, by removing the cap and installing the meter. The gas pressure must remain between 7" and 14" during stand-by and unit running heat cycle. If an in-line regulator is used, it must be a minimum of 10 feet from the Munchkin. **It is very important that the gas line is properly purged by the gas supplier or utility. Failure to properly purge the lines or improper line sizing, will result in the failure of the Munchkin lighting off.** This problem is especially noticeable in NEW LP installations, and also in empty tank situations. This can also occur when a utility company shuts off service to an area to provide maintenance to their lines. This valve must not be replaced with a conventional valve under any circumstances. As an additional safety feature, this valve has a flanged connection to the Venturi and blower.

PART 4

VENTING

4-A. ALL MODELS 3" VENTED

WARNING!!

It is extremely important to follow these venting instructions exactly. Failure to follow the venting instructions can cause severe personal injury, death or substantial property damage.

The inlet pipe on the back of the cabinet, use 3" PVC schedule 40. It is very important that you plan the location properly, to eliminate long pipe runs and excessive fittings. Inlet pipe size must not be reduced. Do not combine the inlet air with any other inlet pipe including an inlet to an additional similar appliance. The joints must be properly cleaned, primed, and cemented. The piping must also be properly supported as per Local and National Standard Plumbing Codes. It is important that the piping must be clean and free from burs, debris, ragged ends, and particles of PVC.

Exhaust pipe on the back of the cabinet will use 3" PVC, CPVC, ABS Schedule 40 or 80. For concrete construction or to meet certain fire codes, exhaust piping inlet air pipe must be 3" CPVC Schedule 40 or 80, (only to meet local fire codes). The balance of the inlet and exhaust piping may be PVC Schedule 40 or 80, or ABS solid only, **NOT FOAM CORE**.

The only approved exhaust vent materials are PVC Schedule 40 (**NOT FOAM CORE PIPE!**). Exhaust piping should be sloped back to the connection on the Munchkin, at least ..." per foot to remove additional condensate that forms within the pipe. The total combined length of pipe (intake piping plus exhaust piping added together) including elbow allowances intake and exhaust (each elbow = 5' of pipe) should not exceed 85'. The combined vent length should not be less than a combined length of 6' plus two 90 degree elbows. Choose your vent termination locations carefully. You must additionally make certain that exhaust gas does not re-circulate back into the intake pipe. You must place them in an open area, and follow the following guidelines.

- 1) Never vent into a walkway, patio area, alley or otherwise public area less than 7' from the ground.
- 2) Never vent over or under a window or over a doorway.
- 3) Never install a heat saver or similar product to capture waste heat from exhaust.
- 4) Always have vent location at least 1' above maximum snow level.
- 5) Always have vent 1' above ground level, away from shrubs and bushes.
- 6) Follow local gas codes in your region or refer to National Fuel Gas Code, Can B149.
- 7) Always have vent at least 3' from an inside corner of outside walls.
- 8) Maintain at least 4' clearance to electric, gas meters, and exhaust fans or inlets.
- 9) **Very Important!** Inlet air must be taken from **outside** of building, next to exhaust outlet, no closer than 8".
- 10) Always place screens in all openings in intake and exhaust to prevent foreign matter from entering the Munchkin.
- 11) The vent intake and exhaust must be properly cleaned and glued for a pressure tight joint. Several methods for venting the Munchkin can be found in Figures 1 thru 6. Use the following layout as a guideline; certain site conditions such as multiple roof lines/pitches may require venting modifications (consult factory). The air inlet must be a minimum of 1' vertically above the maximum snow level or 24" which ever is greater. The air inlet must also be a minimum of 10' horizontally from the roof, and terminated with a tee. The exhaust must be a minimum of 24" above the air inlet opening and terminated with a coupling. It is very important that there are no other vents, chimneys or air inlets in any direction for at least 4'.

All venting must be properly supported, as the Munchkin is not intended to support any venting whatsoever. All piping, glue, solvents, cleaners, fittings and components, must conform to ASTM (American Society for Testing and Materials), and ANSI (American National Standard Institute).

- 12) It is recommended that you use one of the optional vent kits specifically for Munchkin installations.(KGAVT0601CVT (3 in.) or V1000). NOTE: WHEN USING THE HGAVTT601CVT KIT, REMOVE THE 2 SCREENS FROM THE PROVIDED INLET TEE AND INSTALL THEM IN THE INLET SOCKET AND OUTLET SOCKET OF THE KIT PRIOR TO INSTALLING THE SCHEDULE 40 PIPE AND GLUING

4-B. FOR LONGER VENT LENGTHS

All venting must be 3", both intake and exhaust, **NEVER use any piping less than 3", or different size pipe on the intake and exhaust.** You may use 4" venting on both intake and exhaust, to lower the pressure drop, to provide additional venting length. **It is imperative when using 4", to follow these instructions very carefully. For longer lengths, the first 10' of both the intake and exhaust piping are 3". For the intake 10' of 3" PVC Schedule 40 pipe plus one 90 degree or two 45 degree elbows and for the exhaust 10' of PVC Schedule 40 pipe, NOT FOAM CORE, or CPVC plus one 90 degree or two 45 degree elbows.** Use a 4" x 3" PVC reducing coupling. Then proceed with PVC 4" (NOT FOAM CORE) pipe and fittings for both the intake and exhaust piping. On 4" piping you may go an additional 125 equivalent feet of pipe and fittings for a combined total length. The 4" fittings have a friction loss allowance as follows: 4" 90 degree = 3', and a 4" 45 degree = 1'. **The total maximum venting length can be 125', plus the first 10' of each 3" and a maximum fitting allowance of the 3", total two 90 degree or four 45 degree before increasing to 4". Total equivalent would be 30' of 3" plus 125' of 4". Never use different pipe sizes for intake and exhaust. The vent system must be balanced by a friction loss equivalent.**

NOTE:

THE METHODS DESCRIBED ARE SUGGESTED GENERIC METHODS ONLY. SPECIFIC JOB SITE OBSERVATIONS AND SIZING MAY REQUIRE ALTERNATE INSTALLATION METHODS. CONSULT THE FACTORY WITH SPECIFIC JOB REQUIREMENTS FOR ADDITIONAL RECOMMENDATIONS.

4-C. VENTING TABLE

Note: Do not exceed the total combined length of pipe (intake piping plus exhaust piping added together) including fitting allowances shown below should not exceed 85'. The table shows the friction loss for plastic pipe and fitting in 3" and 4" sizes.

FRICITION LOSS EQUIVALENCE TABLE

JOB EXAMPLE:

Note: this example totals both intake and exhaust piping.

4 pcs. - 3" 90 = 20' ; 20' - 3" PVC SCH. 40 PIPE = 20'

40' Total combined length is under max allowable vent run of 85'

This job is okay!

3" VENTED MODELS EQUIVALENT TABLE

FITTING DESC.	EQUIVALENT FEET OF PIPE
3" 90	5'
3" 45	3'
3" COUPLING	0'
3" TEE	0'
3" PIPE	1'=1'
3' CONCENTRIC VENT KIT	3'
3' V1000 VENT KIT	0'

(AFTER THE FIRST 10' OF 3" ONLY)
4" VENTED MODELS
EQUIVALENT TABLE

FITTING DESC.	EQUIVALENT FEET OF PIPE
4" 90	3'
4" 45	1'
4" COUPLING	0'
4" PIPE	1'=1'
4" TEE	0'

VENTING EXAMPLES				
TOTAL COMBINED VENT LENGTH (FEET) INTAKE & EXHAUST	QTY. OF 90* ELBOWS	EQUIVALENT FRICTION LOSS (FEET) FOR EACH ELBOW	TOTAL FRICTION LOSS FOR ELBOWS	GRAND TOTAL VENT LENGTH (FEET) WITH FITTING FRICTION LOSS ADDED
*12	2	5	10	22
20	2	5	10	30
20	3	5	15	35
20	4	5	20	40
20	5	5	25	45
20	6	5	30	50
20	7	5	35	55
20	8	5	40	60
20	9	5	45	65
20	10	5	50	70
30	3	5	15	45
30	4	5	20	50
30	5	5	25	55
30	6	5	30	60
30	7	5	35	65
30	8	5	40	70
40	3	5	15	55
40	4	5	20	60
40	5	5	25	65
40	6	5	30	70
50	3	5	15	65
50	4	5	20	70

4-D. CLEANER / CEMENT

Cement for Exhaust and Intake piping, must conform to ASTM D-2564 for joining PVC joints. Make sure to check all joints to assure that they are properly sealed against leaks. It is important to pay special attention to the exhaust piping, which is pressurized with harmful gases!

4-E. CONDENSATE

This is a condensing high efficiency appliance, therefore this unit has a condensate removal system. Condensate is nothing more than water vapor, derived from the combustion products, similar to an automobile when it is initially started. This condensate does have a low PH and should be treated with a condensate filter. This filter contains either lime crystals or marble crystals, which will neutralize the condensate. The outlet of the filter is sized for 5/8" ID (Inside diameter) plastic tubing. It is very important that the condensate line is sloped away from and down to a suitable inside drain, if the condensate outlet on the Munchkin is lower than the drain, you must use a condensate removal pump. A condensate filter and a condensate pump kit are available from HTP. It is also very important that the condensate line is not exposed to freezing temperatures, or any other type of blockage. Plastic tubing should be the only material used for the condensate line. Steel, brass, copper or others will be subject to corrosion and deterioration. A second vent may be necessary to prevent condensate line vacuum lock if a long horizontal run is used. Also, an increase to 1" tubing may be necessary.

VENTING DIAGRAMS 4-F.

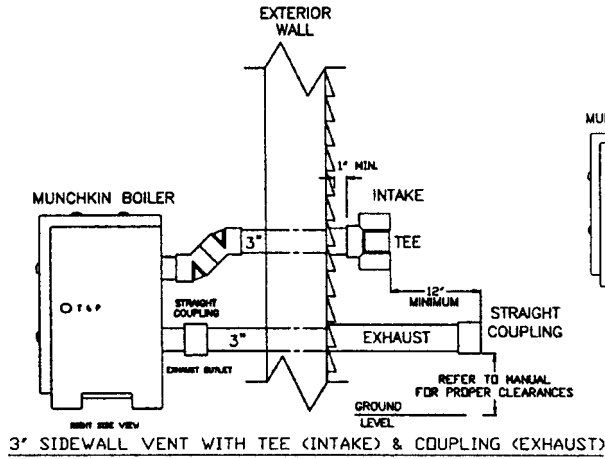
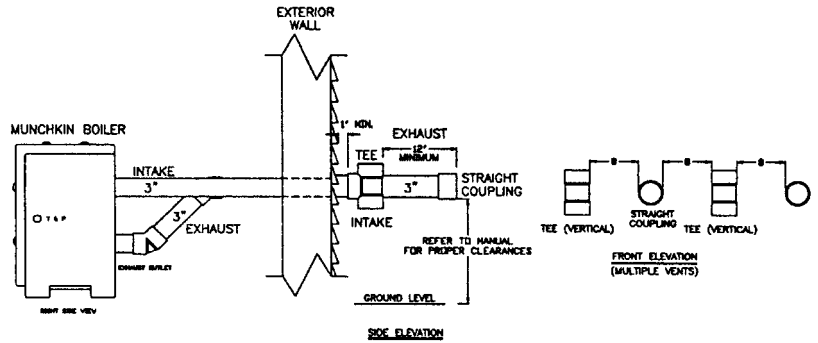

FIGURE 1

***IMPORTANT NOTE: ALL VENT PIPES MUST BE GLUED, PROPERLY SUPPORTED, AND THE EXHAUST MUST BE PITCHED A MINIMUM OF A 1/4\"/>



3\"/>

FIGURE 2

***IMPORTANT NOTE: ALL VENT PIPES MUST BE GLUED, PROPERLY SUPPORTED, AND THE EXHAUST MUST BE PITCHED A MINIMUM OF A 1/4\"/>

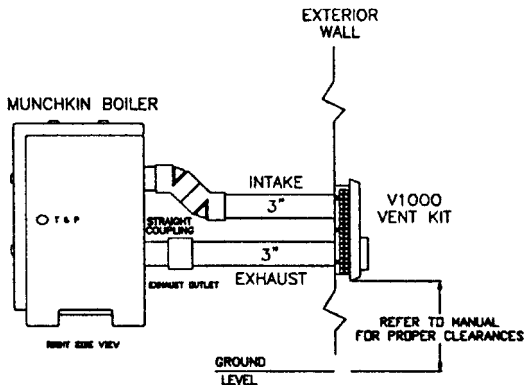

3\"/>

FIGURE 3

***IMPORTANT NOTE: ALL VENT PIPES MUST BE GLUED, PROPERLY SUPPORTED, AND THE EXHAUST MUST BE PITCHED A MINIMUM OF A 1/4\"/>

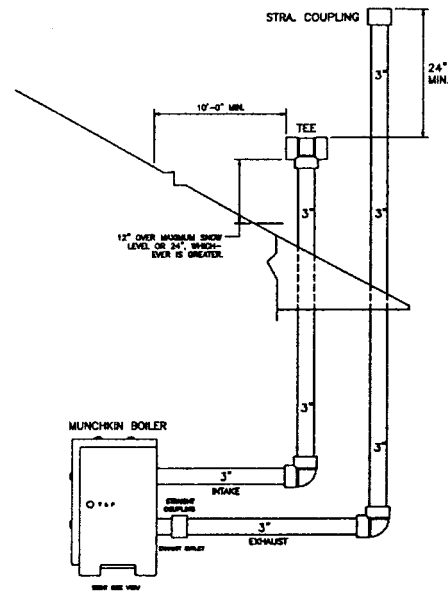

3\"/>

FIGURE 4

***IMPORTANT NOTE: ALL VENT PIPES MUST BE GLUED, PROPERLY SUPPORTED, AND THE EXHAUST MUST BE PITCHED A MINIMUM OF A 1/4\"/>

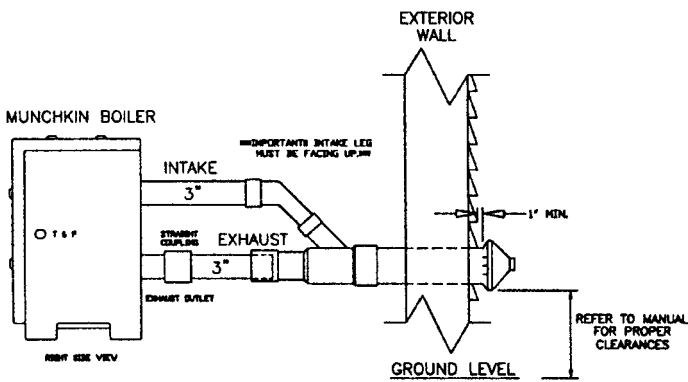

3\"/>

FIGURE 5

***IMPORTANT NOTE: ALL VENT PIPES MUST BE GLUED, PROPERLY SUPPORTED, AND THE EXHAUST MUST BE PITCHED A MINIMUM OF A 1/4\"/>

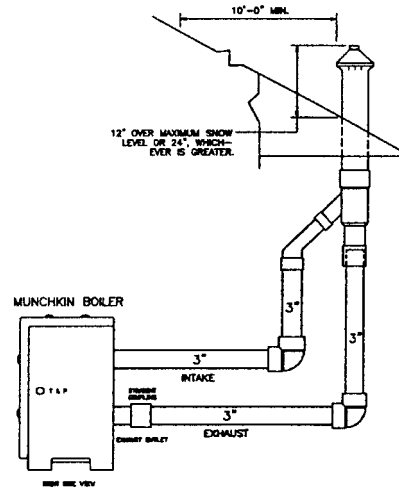

3\"/>

FIGURE 6

IMPORTANT NOTE: ALL VENT PIPES MUST BE GLUED, PROPERLY SUPPORTED, AND PITCHED A MINIMUM OF A QUARTER INCH PER FOOT BACK TO THE BOILER (TO ALLOW DRAINAGE OF CONDENSATE).

PART 5

5-A. HYDRONIC HEAT PIPING

The Munchkin is designed to function in a closed loop 15 PSI System. To assure that there is adequate pressure in the system, we have installed in the Outlet Manifold, a pressure switch which will not let the Munchkin operate without a minimum of 10 PSI water pressure. This assures that the system does not have a leak, which could cause damage to the Munchkin System. It is Important to note that the Munchkin Boiler does have minimal amount of pressure drop and must be figured in when sizing the circulator to the System (See Figure 7B). Each Munchkin System must have an Air Eliminator, which is designed to be installed in the Boiler Return Pipe (boiler in) which will remove air from the Hydronic System. Always follow good piping practices. Observe minimum 1" clearance to combustibles around all uninsulated hot water pipes or when openings around pipes are not protected by non-combustible materials. On a Munchkin installed above radiation level, some states and local codes require a low water cut off device at the time of installation by the installer. If the Munchkin supplies hot water to heating coils in air handlers units, flow control valves or other devices must be installed to prevent gravity circulation of boiler water in the coils during the cooling cycle.

CAUTION!!

**THE MUNCHKIN SHOULD NOT BE OPERATED AS A PORTABLE HOT WATER HEATER.
IT IS NOT TO BE USED AS A DIRECT DOMESTIC HOT WATER APPLIANCE.**

Basic steps are listed below, with an Illustration, which will guide you through the installation of the Munchkin

1. Pipe properly. In accordance to (Figure 7A).
2. Connect system return marked "**BOILER IN**", make sure to install with pipe sealant compound. Threaded connection are 1..." NPT brass nipples.
3. Connect system supply marked "**BOILER OUT**". Make sure to install with pipe sealant compound. Threaded connection are 1..." NPT brass nipple.
4. Install **Purge and Balance Valve** on system return.
5. Install **Back Flow Preventer** if required by local codes on system return.
6. Install **Pump** on system supply. Make sure pump is properly sized for piping loss.
7. Install on **Cold Water Feed Pressure Reducing Valve**. (15 PSI nominal on system return). Check temperature/ pressure gauge should read minimum of 12 PSI.
8. Install **Expansion Tank** on system supply. Use appropriate size tank for volume of water in system.
9. Install **Air Vent** on system return.
10. Install **Flow Check** on system supply.
11. Install **Drain Valve** on system supply. Note Munchkin can not be drained of water without purging the unit with air pressure 15 PSI minimum.
12. Install Temperature/ pressure gauge on system supply.

5-B. FILL AND PURGE HEATING SYSTEM

Attach hose to balance and purge hose connector and run to drain.

Close the other side of the balance and purge valve.

Open first zone balance and purge valve, so as to let the water flow out of the hose. If zone valves are used, open zone valves one at a time, manually. (NOTE: please check manufacturers' instructions prior to opening valves manually, so not to damage valve.)

Manually operate fill valve regulator. When the water runs out of the hose, while it's connected to the balance and purge valve you will see a steady stream (with no air bubbles). Close balance and purge valve to stop the water from flowing. Disconnect hose and connect to next zone to be purged.

Repeat procedure for additional zones (one at a time).

Upon completion, make sure that the fill valve is in automatic position and each zone balance and purge valve is in the open position and zone valves are positioned for automatic operation.

NOTE: For installation that incorporates Standing Iron Radiation and systems manual vents high points. Follow the Section 5-B procedure, then starting with the nearest manual air vent, open vent until water flows out, then close vent. Repeat procedure, working your way toward furthest air vent. It may be necessary to install basket strainer in an older hydronic system where larger amounts of sediment may be present. Annual cleaning of the strainer may be necessary.

SUGGESTED HYDRONIC PIPING FOR MUNCHKIN BOILER

FIGURE 7A

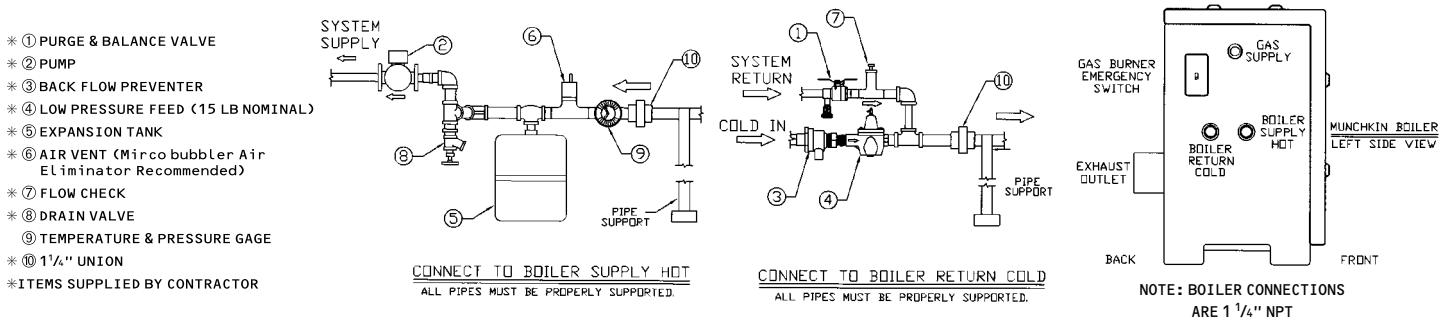
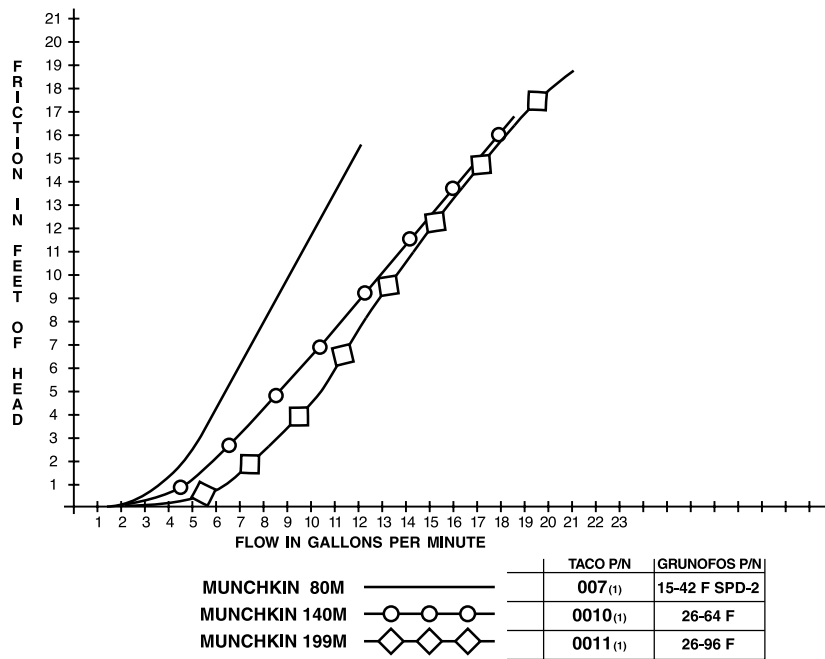

FIGURE 7B



1) THE RECOMMENDED CIRCULATORS ARE BASED ON 1 GPM PER 10,000 BTU/HR W/20° Δt

PART 6

BOILER START UP

6-A. COMMON VENT TEST

At the time of removal of an existing boiler, the following steps shall be followed with each appliance remaining connected to the common venting system placed in operation, while the other appliances remaining connected to the common venting system are not in operation.

1. Seal any unused openings in the common venting system.
2. Visually inspect the venting system for proper size and horizontal pitch to determine there is no blockage or restriction, leakage, corrosion and other deficiencies which could cause an unsafe condition.
3. If practical, close all building doors, windows and all doors between the space in which the appliances remain connected to the common venting system are located and other spaces of the building. Turn on clothes dryers and any appliances not connected to the common venting system. Turn on any exhaust fans, such as range hoods and bathroom exhausts, at maximum speed. Do not operate a summer exhaust fan. Close fireplace dampers.

4. Place in operation the appliance being inspected. Follow the lighting instructions. Adjust thermostat so appliance will operate continuously.
5. Test for spillage at the draft hood relief opening after 5 minutes of main burner operation. Use the flame of a match or candle, or smoke from a cigarette, cigar or pipe.
6. After it has been determined that each appliance remaining connected to the common venting system properly vents when tested as outlined above, return doors, windows, exhaust fans, fireplace dampers and any other gas-burning appliance to their previous condition of use.
7. Any improper operation of the common venting system should be corrected so the installation conforms with the National Fuel Gas Code, ANSI Z223.1. When resizing any portion of the common venting system, the common venting system should be resized to approach the minimum size as determined using the appropriate tables in Appendix G in the National Fuel Gas Code, ANSI Z223.1

6-B. ITEMS TO BE CHECKED BEFORE LIGHTING THE MUNCHKIN

READ SECTION 1-A (OPERATION)

1. **Make sure you have minimum 10 psi water pressure. The water pressure switch will not allow the unit to run without 10 psi.**
2. **Check all molex plugs, making sure they are properly connected into each plug.**
3. **Check clear hose connection from pressure switch to outlet of blower.**
4. **Make sure gas is turned on.**

WARNING!!

If you smell gas. Shut gas off. Following the instructions in Section 'B' in 6-C/Lighting Instructions in Safety Information on next page.

5. **Double check temperature setting and differential settings.**
6. **Make sure that unit is properly ground, and black (hot), white (neutral lead) are connected properly. Note: If not properly grounded or black (hot), white (neutral lead) are reversed then the unit will light for 3-4 seconds then shut-off after three cycles.**
7. **Turn power on to the Munchkin.**
8. **Check to see that the LED light indicator is illuminated.**

6-C. LIGHTING INSTRUCTIONS

FOR YOUR SAFETY READ BEFORE OPERATING

WARNING!!

If you do not follow these instructions exactly, a fire or explosion may result, causing property damage, personal injury or loss of life.

- A. This appliance does not have pilot. It is equipped with an ignition device which automatically lights the burner. Do not try to light the burner by hand.
- B. BEFORE OPERATING smell all around the appliance area for gas. Be sure to smell next to the floor because some gas is heavier than air and will settle on the floor.
WHAT TO DO IF YOU SMELL GAS
Do not try to light any appliance.
Do not touch any electric switch; do not use any phone in your building.
Immediately call your gas supplier from a neighbor's phone. Follow the gas suppliers' instructions.
If you cannot reach your gas supplier, call the fire department.
- C. Turn on gas shutoff valve (located on the top of the Boiler) so that the handle is aligned with the gas pipe. If the handle will not turn by hand, don't try to repair it, call a qualified service technician. Force or attempted repair may result in a fire or explosion.
- D. Do not use this appliance if any part has been under water. Immediately call a qualified service technician to inspect the appliance and to replace any part of the control system and any gas control which has been under water.

OPERATING INSTRUCTIONS

- 1. STOP! Read the safety information above.
- 2. Set the thermostat to lowest setting.
- 3. Turn off all electric power to the appliance.
- 4. This appliance is equipped with an ignition device which automatically lights the burner. Do not try to light the burner by hand.
- 5. Remove front cover.
- 6. Turn gas shutoff valve clockwise to "off". Handle will be vertical, do not force.
- 7. Wait five (5) minutes to clear out any gas. If you then smell gas, STOP! Follow Section 'B' in 6-C/Lighting Instructions in the safety information above on this label. If you don't smell gas, go to next step.
- 8. Turn gas shutoff valve counter clockwise to "on". Handle will be horizontal.
- 9. Install Front Cover.
- 10. Turn on all electric power to appliance.
- 11. Set thermostat to desired setting.
- 12. If the appliance will not operate, follow the instructions "To Turn Off Gas To Appliance" and call your service technician or gas supplier.

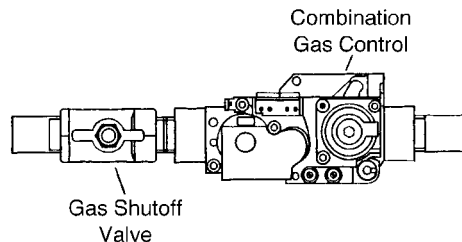

TO TURN OFF GAS TO APPLIANCE

- 1. Set the thermostat to lowest setting.
- 2. Turn off all electric power to the appliance if service is to be performed.
- 3. Remove front cover.
- 4. Turn gas shutoff valve clockwise to "off". Handle will be vertical. Do not force.
- 5. Install front cover.

PART 7 SERVICING

7-A. SEQUENCE OF OPERATION

1. When power is first applied to the control, the control will initially run through a self-diagnostic routine and then go into its operating mode. If there is no call for heat, the System will go into the idle state.
2. If the thermostat is calling for heat, the control will apply power to the circulator pump. If the control determines the appliance water temperature is below the programmed set point value less the switching differential, the control will initiate a heating cycle.
3. The control then performs selected system diagnostic checks. If all checks are successfully passed, a pre-purge cycle is initiated (blower on max speed).
4. When the pre-purge period is complete, power is applied to the spark ignitor for approximately 6 seconds. Approximately 2 seconds later, we verify flame. If a flame is not verified during the trial-for-ignition, the gas valve is immediately closed and the control will return to step 2. If after three trials a flame is not verified, the control will go into lockout mode. If a flame is confirmed, the control enters the heating mode. Fire rate based on the proprietary algorithm.
5. When water temperature reaches the temperature set point valve plus 10 degrees F (or if the thermostat call-for-heat is satisfied), the gas valve is closed and the control enters post-purge (blower on max speed). **NOTE: IF THE THERMOSTAT IS STILL CALLING FOR HEAT, THE CIRCULATOR PUMP WILL CONTINUE TO RUN UNTIL THE THERMOSTAT CALL FOR HEAT IS SATISFIED.**
6. When post-purge is complete, the control enters the idle state while continuing to monitor temperature and the state of other system devices. If a call-for-heat is received, the control will automatically return to step 2 and repeat the entire operating cycle.

During the idle state and heat state, if the control detects an improper operating state for external devices such as the high-limit switch, the green LED on the control will flash an error code sequence.

7-B. ADJUSTMENT SET POINTS AND DIFFERENTIAL SETTINGS

1. Temperature Adjustment- A potentiometer located on the control board is used to adjust the set point temperature on the boiler appliance. This can be set between 70 and 210 degrees.
2. Temperature Differential Adjustment - A "DIP" switch is located on the control board. Depending upon the configuration of the "DIP" switch, the differential selection is 6, 12, 20, or 30. See the figure below for further detail.

NOTE: the differential adjustment is the value below the set point, when the burner will fire. (Example: 190 degree set point, 30 degrees differential, burner will not fire until return water drops below 160 degrees and will modulate the flame until 190 degrees is reached, then post purge and idle state will be achieved. If at any point TT is satisfied, the cycle will be interrupted by post purge and idle state.

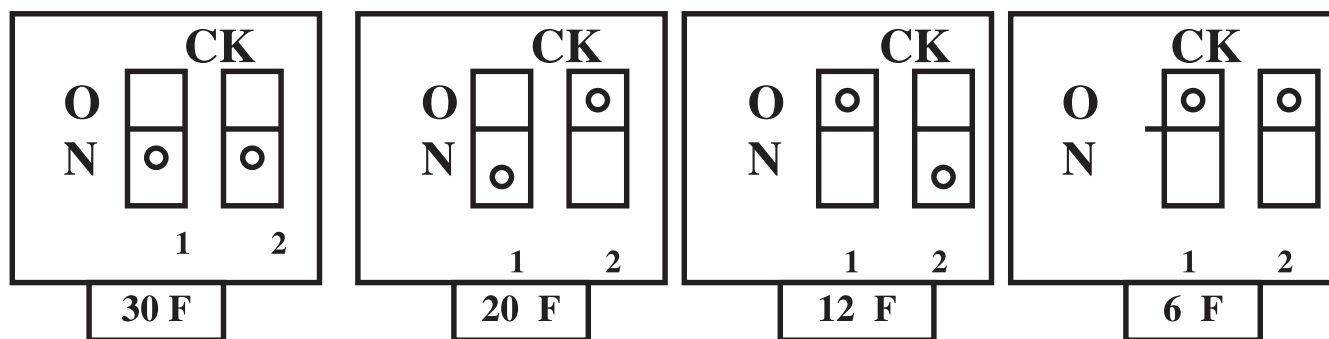

7-C MUNCHKIN BOILER FAULT LED CODE:

When a fault condition occurs or is sensed on the WHC1100 Munchkin Controller or in the appliance, the control board goes to a LOCKOUT state. When in the LOCKOUT state, the green LED located on the WHC1100 Control board will flash a fault code. The number of times the LED flashes ON/OFF will determine the nature of the fault (see the table below). To reset the Control from the LOCKOUT state, remove and re-apply 120VAC line power to the Control board.

<u>DESCRIPTION of FAULT</u>	<u># of LED PULSES</u>
Limit String Open, Water Pressure Switch, ECO s	2
Flame Stuck ON	3
Ignition Fault (No Flame)	4
Inlet Probe Fault	5
Outlet Probe Fault	6
Air Pressure Switch Fault, Stuck Closed	7
Air Pressure Switch Fault, Stuck Open	8
Redundant Gas Valve Relay Stuck ON	9
Gas Valve Relay Stuck ON	9
Redundant Gas Valve Relay Stuck OFF	10
Gas Valve Relay Stuck OFF	10
Gas Valve wire disconnected	11
ROM Checksum Failure	12
RAM Test Failure	13
60 Hz Failure	14

NOTE: To read LED flashes 1 flash per second within sets of flashes with 2-second wait periods between sets of flashes. During normal operation, the LED will pulse continuously.

7-D FAULT CONDITIONS

Limit String Open, High Limit Failure — 2 PULSES

- If the limit string opens, the control will immediately remove power to the gas valve, complete a post purge cycle and enter a lockout state. To restart the control, make sure that there is at least 10 PSI in the water system, then remove and re-apply 120 VAC line power.

NOTE: The bi-metallic high limit device must physically close before the control board will function properly. If a user recycles power to restart the control and the high limit device is still open, the control will revert back to the lockout state 2 LED PULSES.

- If the control senses a fault in the limit string, the control will immediately remove power to the gas valve. After completing a post purge cycle, the control will go into the lockout state.

Flame Stuck ON — 3 PULSES

- The current state of the flame may be determined by looking through the view port on the combustion chamber. If the flame is stuck ON/OFF then the flame rod insulator or the connector CN6 may not be clean, or unplugged.

Ignition Failure (No Flame) — 4 PULSES

- If an ignition failure occurs during the trial-for-ignition, the control will return to the pre-purge state and attempt another ignition trial. If after three trials an ignition failure is still occurring, the control will go into the lockout state. Check that the gas valve is operating correctly and the plug is fully connected into the valve. Verify that the gas supply is turned on, that there is a proper connection to the 120VAC line source, that the flame rod is connected and also that the flame rod is clean. Replace the Low-Voltage Cable assembly.

Open Temperature Sensor On Inlet (Probe Fault) — 5 PULSES

- The control will sense an open temperature probe. If an open probe is sensed, the control will go into the lockout state. Verify that the Inlet probe is properly connected to the control board. If the temperature probe is in an environment of less than 0°F then wait for ambient temperature to rise or apply heat to the unit. If the temperature probe is in an environment of more than 230°F then wait for the temperature to lower below 200°F

Open Temperature Sensor On Outlet (Probe Fault) — 6 PULSES

- The control will sense an open temperature probe. If an open probe is sensed, the control will go into the lockout state. Verify that the Outlet probe is properly connected to the control board. If the temperature probe is in an environment of less than 0°F then wait for ambient temperature to rise, or apply heat to the unit. If the temperature probe is in an environment of more than 230°F, then wait for the temperature to lower below 200°F

Air Pressure Switch Fault Stuck Closed — 7 PULSES

- If the control senses the blower pressure switch is closed when it is expected to be open, the control will wait approximately 90 seconds for the fault condition to clear. If after approximately 90 seconds the control still senses the blower pressure switch is closed, the control will go into the lockout state. Verify that the blower motor is operational and that the 120VAC power cable is connected to the blower. Check that the wires are connected to the blower air pressure switch and that the air pressure switch is functional. This may require turning the screw in the center of the air pressure switch 1 turn clockwise to correct (Initial set-up only). After any air pressure switch adjustment, you must cycle the appliance several times to insure proper operation.

Air Pressure Switch Fault Stuck Open — 8 PULSES

- If the control senses the blower pressure switch is not closed during the pre-purge cycle, the control will attempt two additional pre-purge trials. If after three pre-purge trials the control is still sensing the blower pressure switch is not closing, the control will enter the lockout state. Check that the blower motor is off and verify that the blower air pressure switch is functional. This may require turning the screw in the center of the air pressure switch in 1/4 turn counter-clockwise to correct- (initial set-up only). After any air pressure switch adjustment, you must cycle the appliance several times to insure proper operation.

Redundant Gas Valve/Gas Valve Relay Stuck ON — 9 PULSES

1. If the controller senses the redundant gas valve or the gas valve relay is stuck ON it will go into the lockout state. Check for short-circuit(s) from the 24VAC and no continuity between CN4 pins 3 & 4. If the problem persists, replace the control board.

Redundant Gas Valve/Gas Valve Relay Stuck OFF — 10 PULSES

1. If the controller senses the redundant gas valve or if the gas valve relay is stuck OFF it will go into a lockout state. Replace the control board.

Gas Valve NOT Connected — 11 PULSES

1. If the controller detects that the gas valve is not connected it will go into the lockout state. Check the connection of the gas valve.

ROM Checksum Failure — 12 PULSES

1. If the controller detects that the ROM check has failed then it will go into a lockout state. Cycle the power from the ON to OFF state. If the problem persists, you may need to replace the control board.

RAM Test Failure — 13 PULSES

1. If the controller detects that the RAM test failed it will go into a lockout state. Cycle the power from the ON to OFF state. If the problem persists, you may need to replace the control board.

60Hz Failure — 14 PULSES

1. If the generator, inverter, or other power source does not provide 60Hz then the power source must be replaced. If the power source used supplies 60Hz then cycle the power from the On to OFF state. If the problem persists, then you may need to replace the control board.

MUNCHKIN CONTROLLER

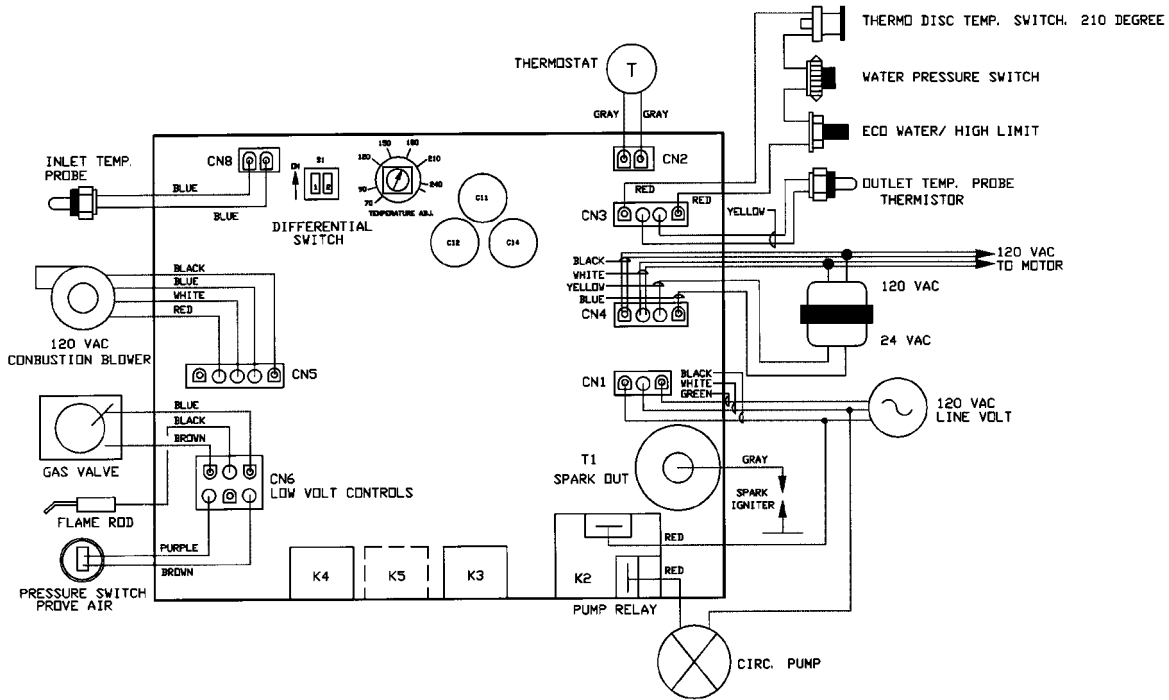

PART 8

8-A. MAINTENANCE PROCEDURES

Periodic maintenance should be performed once a year by a qualified service technician to assure that all the equipment is in safe efficient operation. The owner can make necessary arrangements with a qualified heating contractor for periodic maintenance of the boiler. Installer must also inform owner that the lack of proper care and maintenance of the boiler may result in a hazardous condition. Installer should discuss contents of the User's Information Manual with the owner.

8-B. BEFORE EACH HEATING SEASON:

A trained and qualified service technician should perform the inspections listed below at least once a year.

Boiler - check the boiler for dust or foreign materials, which may have been drawn in from the air intake of the boiler .
Simply blow out or wipe down with a dry rag.

Vent Termination - check to remove any obstructions, such as leaves, bushes, or other sources which may interfere with the units ability to draw fresh air on the air intake or exhaust flue gas from the exhaust outlet.

Vent Piping - make sure that all vent piping is in good condition. Check Joints for possible leaks.

Condensate - check the Condensate trap by simply starting the unit and observing the flow of Condensate which should not be restricted in any fashion.

Heat Exchanger - in the unlikely event boiler flue passage is becoming blocked, service must be performed only by an authorized Heat Transfer Products Representative or Certified Installing Contractor.

Burner - check burner for deterioration. If deterioration is observed, change burner .

System Water / Pressure - check pressure regulator and system pressure. Check system for air which will create noise. Open air vents to bleed air than close once air is fully pur ged from the system.

Water Piping - check for and repair any leaks.

Gas Piping - check for and repair any leaks.

COMPONENTS DIAGRAM

1. BLOWER (80M - 7250P-085)
(140M - 7250P-086)
(199M - 7250P-087)
2. TRANSFORMER (7250P-022)
3. BOARD (80M - 7250P-009)
(140M - 7250P-014)
(199M - 7250P-015)
4. GAS VALVE (7250P-038)
5. ELECTRICAL SWITCH BOX
6. THERMISTOR (7250P-059)
7. WATER PRESSURE SWITCH (7250P-081)
8. AIR PRESSURE SWITCH (7250P-147)
9. T & P VALVE (7250P-080)
10. ECO WATER (7250P-019)
11. THERMODISC TEMP. SWITCH (7250P-019)
210 DEGREE (7250P-089)
12. SPARK ELECTRODE (7250P-058)
13. BURNER (80M - 7250P-042)
(140M - 7250P-043)
(199M - 7250P-044)
14. RECTIFIER (7250P-049)

